

QUINT4-INV/24DC/1AC/600VA/USB - DC/AC inverter



1067325

<https://www.phoenixcontact.com/gb/products/1067325>

Please be informed that the data shown in this PDF document is generated from our online catalog. Please find the complete data in the user documentation. Our general terms of use for downloads are valid.

QUINT INVERTER, DIN rail mounting, input:24 V DC, output:1AC / 600 VA, Pure sine.



Your advantages

- Manual selection of AC output voltage via signal terminal enables worldwide use
- Pure sine curve at the output
- USB interface for connecting to industrial PCs, for example
- Can be switched in parallel for various applications
- Space savings, thanks to the compact design

Technical data

Input data

Input voltage	24 V DC
Input voltage range DC	20 V DC ... 30 V DC
Current consumption	typ. 23 A
	max. 28 A

Signal Remote

Connection labeling	3.8
Signalization designation	Remote
Low signal	Connection to SGnd with < 2.7 kΩ
High signal	Open (> 35 kΩ between Remote and SGnd)

Signal Start 230V

Connection labeling	3.6
Signalization designation	Start 230V
Low signal	Connection to SGnd with < 2.7 kΩ
High signal	Open (> 200 kΩ between Start and SGnd)

Signal Start 120V

Connection labeling	3.7
Signalization designation	Start 120V
Low signal	Connection to SGnd with < 2.7 kΩ
High signal	Open (> 200 kΩ between Start and SGnd)

Output data

Efficiency	> 86 % (120 V AC)
	> 87 % (230 V AC)
Output voltage	120 V AC ±2 % (100 V AC / 6 A...130 V AC / 4,6 A)
	230 V AC ±2 % (200 V AC / 3 A...240 V / 2,5 A)
Form of output voltage	Pure sine
Nominal output current (I _N)	5 A (120 V AC)
	2.6 A (230 V AC)
Maximum no-load power dissipation	typ. 21 W (120 V AC)
	typ. 21 W (230 V AC)
Power loss nominal load max.	typ. 72 W (120 V AC)
	typ. 66 W (230 V AC)
Nominal output frequency	60 Hz 50 Hz ±0.5 %
Derating	50 °C ... 60 °C (2.5 %/K)
Apparent power	600 VA
Real power	480 W
Power factor (cos phi)	0.8
Crest factor	2.8
Total harmonic distortion factor (THD)	< 3 % (linear load)

QUINT4-INV/24DC/1AC/600VA/USB - DC/AC inverter



1067325

<https://www.phoenixcontact.com/gb/products/1067325>

	< 8 % (non-linear load)
Connection in parallel	yes
	max. 3
Connection in series	no
Overload capacity Mains operation	105 % (Permanent)
	120 % ... 150 % (20 s / 5 s, then shutdown)
Electronic current limitation	> 2,5 x I _N (> 200 ms)

Signal AC OK

Connection labeling	3.2
Signalization designation	AC OK
Type of signaling	Green LED
Switching output	Transistor output, active
Output voltage	24 V
Continuous load current	≤ 20 mA
LED status indicator	green

Signal Alarm

Connection labeling	3.1
Signalization designation	Alarm
Type of signaling	LED red
Switching output	Transistor output, active
Output voltage	24 V
Continuous load current	≤ 20 mA
LED status indicator	red

Signal DC OK

Connection labeling	3.3
Signalization designation	DC OK
Switching output	Transistor output, active
Output voltage	24 V
Continuous load current	≤ 20 mA
LED status indicator	green

Signal Parallel run

Connection labeling	3.5
Signalization designation	Parallel run
Switching output	Transistor output, active
Continuous load current	≤ 20 mA

Signal P>P_n

Connection labeling	3.4
Signalization designation	P>P _n
Switching output	Transistor output, active
Continuous load current	≤ 20 mA
LED status indicator	green

1067325

<https://www.phoenixcontact.com/gb/products/1067325>

Signal ground SGnd

Connection labeling	3.9
Function	Signal ground
Reference potential	For signal inputs and signal outputs

Connection data

Input

Position	1.x
----------	-----

Conductor connection

Connection method	Screw connection
rigid	0.2 mm ² ... 6 mm ²
flexible	0.2 mm ² ... 4 mm ²
flexible with ferrule without plastic sleeve	0.2 mm ² ... 4 mm ²
flexible with ferrule with plastic sleeve	0.2 mm ² ... 4 mm ²
rigid (AWG)	30 ... 10
Stripping length	8 mm
Tightening torque	0.5 Nm ... 0.6 Nm
Drive form screw head	Slotted L

Output

Position	2.x
----------	-----

Conductor connection

Connection method	Screw connection
rigid	0.2 mm ² ... 6 mm ²
flexible	0.2 mm ² ... 4 mm ²
flexible with ferrule without plastic sleeve	0.2 mm ² ... 4 mm ²
flexible with ferrule with plastic sleeve	0.2 mm ² ... 4 mm ²
rigid (AWG)	30 ... 10
Stripping length	8 mm
Tightening torque	0.5 Nm ... 0.6 Nm
Drive form screw head	Slotted L

Signal

Position	3.x
----------	-----

Conductor connection

Connection method	Screw connection
rigid	0.2 mm ² ... 1.5 mm ²
flexible	0.2 mm ² ... 1.5 mm ²
flexible with ferrule without plastic sleeve	0.2 mm ² ... 1.5 mm ²
flexible with ferrule with plastic sleeve	0.2 mm ² ... 1.5 mm ²
rigid (AWG)	30 ... 12
Stripping length	8 mm

QUINT4-INV/24DC/1AC/600VA/USB - DC/AC inverter



1067325

<https://www.phoenixcontact.com/gb/products/1067325>

Tightening torque	0.5 Nm ... 0.6 Nm
Drive form screw head	Slotted L

Interfaces

Interface	USB (Modbus/RTU)
Number of interfaces	1
Connection method	MINI-USB Type B
Connection marking	5.1
Locking	Screw
Transmission physics	USB 2.0
Features	lockable
Maximum cable length	3 m
Electrical isolation	yes
Interface	Parallel Port
Number of interfaces	1
Connection method	RJ45
Connection marking	5.2
Locking	Locking clip
Electrical isolation	yes

Electrical properties

Number of phases	1.00
------------------	------

Product properties

Product type	DC/AC inverters
Product family	QUINT INVERTER
MTBF (IEC 61709, SN 29500)	532525 h (40 °C)

Insulation characteristics

Protection class	I
Degree of pollution	2

Dimensions

Item dimensions

Width	180 mm
Height	130 mm
Depth	125 mm

Installation dimensions

Installation distance right/left	0 mm / 0 mm
Installation distance top/bottom	50 mm / 50 mm

Mounting

Mounting type	DIN rail mounting
---------------	-------------------

Material specifications

Housing material	Metal
------------------	-------

Environmental and real-life conditions

Ambient conditions

Degree of protection	IP20
Ambient temperature (operation)	-25 °C ... 60 °C (> 50 °C: 2,5 % / K)
Ambient temperature (storage/transport)	-40 °C ... 85 °C
Maximum altitude	≤ 3000 m (> 2000 m: 0,6 % / 100 m)
Max. permissible relative humidity (operation)	≤ 95 %
Shock	20g in all directions (EN 60068-2-27)
Vibration (operation)	5 Hz ... 100 Hz, 0.7g (EN 60068-2-6)

Standards and regulations

Overvoltage category

EN 61010-2-201	II
----------------	----

Approvals

UL

Identification	UL/C-UL Recognized UL 1778
----------------	----------------------------

UL

Identification	UL/C-UL Listed UL 61010-1
----------------	---------------------------

UL

Identification	UL/C-UL Listed UL 61010-2-201
----------------	-------------------------------

EMC data

Low Voltage Directive	Conformance with Low Voltage Directive 2014/35/EC
Interference emission	Noise emission in accordance with EN 61000-6-4
Noise immunity	Immunity in accordance with EN 61000-6-2
Electromagnetic compatibility	Conformance with EMC Directive 2014/30/EU
Conducted noise emission	EN 61000-6-4

Electrostatic discharge

Standards/regulations	EN 61000-4-2
-----------------------	--------------

Electrostatic discharge

Contact discharge	± 6 kV
Discharge in air	± 8 kV
Comments	Criterion A

Electromagnetic HF field

Standards/regulations	EN 61000-4-3
-----------------------	--------------

QUINT4-INV/24DC/1AC/600VA/USB - DC/AC inverter



1067325

<https://www.phoenixcontact.com/gb/products/1067325>

Electromagnetic HF field

Frequency range	80 MHz ... 6 GHz
Test field strength	10 V/m
Comments	Criterion A

Fast transients (burst)

Standards/regulations	EN 61000-4-4
-----------------------	--------------

Fast transients (burst)

Input	± 2 kV
Output	± 2 kV
Signal	± 2 kV ± 2 kV (USB)
Comments	Criterion A (B for USB)

Surge voltage load (surge)

Standards/regulations	EN 61000-4-5
-----------------------	--------------

Surge voltage load (surge)

Input	± 1 kV (symmetrical) ± 2 kV (asymmetrical)
Output	± 1 kV (symmetrical) ± 2 kV (asymmetrical)
Signal	1 kV (asymmetrical)
Comments	Criterion B

Conducted interference

Standards/regulations	EN 61000-4-6
-----------------------	--------------

Conducted interference

Frequency range	0.15 MHz ... 80 MHz
Signal	10 V
Comments	Criterion A

Power frequency magnetic field

Standards/regulations	EN 61000-4-8
Frequency	50 Hz 60 Hz
Signal	30 A/m
Comments	Criterion A

Criteria

Criterion A	Normal operating behavior within the specified limits.
Criterion B	Temporary impairment to operational behavior that is corrected by the device itself.

Drawings

Diagram

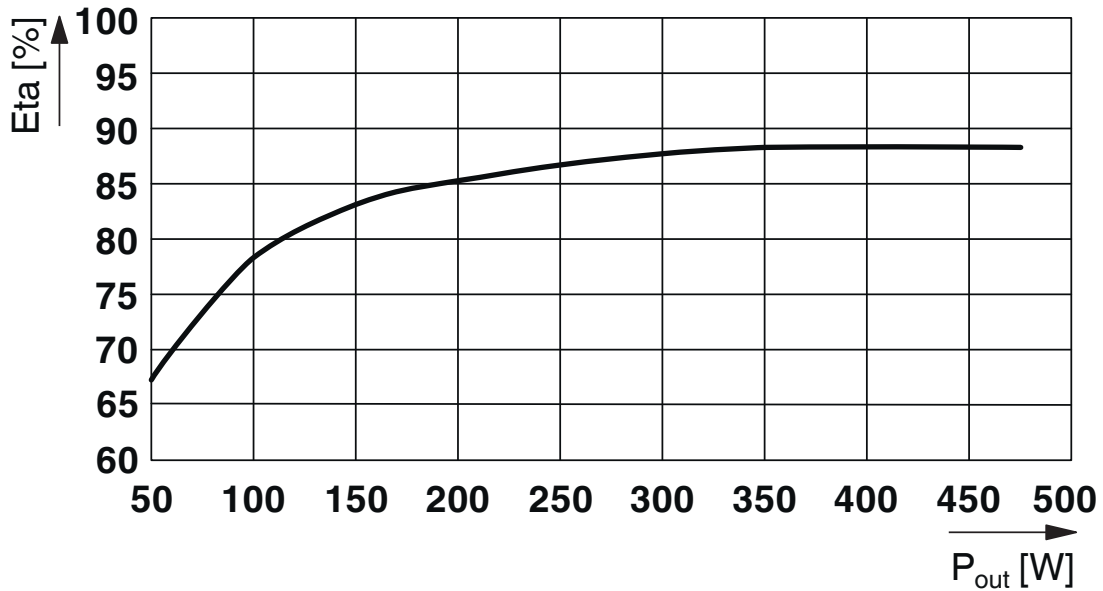

Efficiency

Block diagram

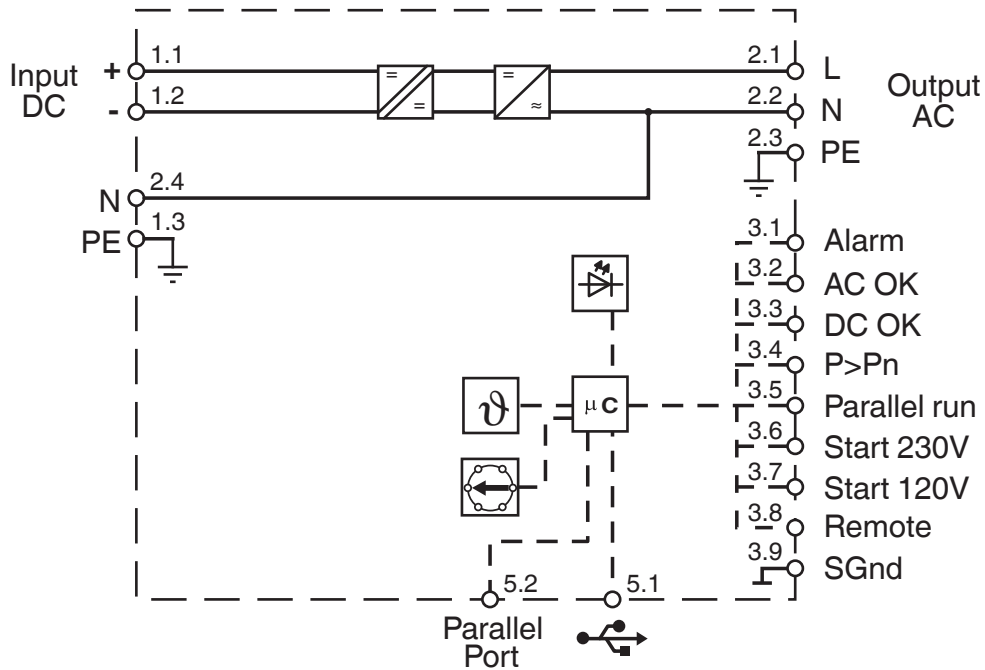

Block diagram

QUINT4-INV/24DC/1AC/600VA/USB - DC/AC inverter



1067325

<https://www.phoenixcontact.com/gb/products/1067325>

Phoenix Contact 2024 © - all rights reserved
<https://www.phoenixcontact.com>

PHOENIX CONTACT Ltd
Halesfield 13, Telford
Shropshire, TF7 4PG
01952 681700
info@phoenixcontact.co.uk