

AMG FIM-C EX**Weidmüller Interface GmbH & Co. KG**

Klingenbergstraße 26

D-32758 Detmold

Germany

www.weidmueller.com



Similar to illustration

Efficient machine and facility operation calls for fail-safe and maintenance-friendly control voltage distribution that can be installed in a time and space-saving manner.

With the new maxGUARD system, the terminal blocks (previously installed separately) for distributing potential to the outputs of the electronic load monitors become an integral part of a 24 V DC control voltage distribution system.

The innovative combination of load monitoring and potential distribution saves time during installation, increases safety against failure and reduces the amount of space required on the terminal rail by 50%.

General ordering data

Version	Supply module, 24 V DC
Order No.	2082540000
Type	AMG FIM-C EX
GTIN (EAN)	4050118419719
Qty.	1 pc(s).

AMG FIM-C EX

Weidmüller Interface GmbH & Co. KG

Klingenbergstraße 26

D-32758 Detmold

Germany

www.weidmueller.com

Technical data

Dimensions and weights

Depth	96.5 mm	Depth (inches)	3.799 inch
Height	125 mm	Height (inches)	4.921 inch
Width	12.2 mm	Width (inches)	0.48 inch
Net weight	78 g		

Temperatures

Storage temperature	-40 °C...85 °C	Operating temperature	-25 °C...70 °C
---------------------	----------------	-----------------------	----------------

Input

Connection system	PUSH IN	Current consumption (full load)	120 mA
Current consumption (idle)	20 mA	DC input voltage range	18...30 V DC
Input fuse (internal)	No	Rated input voltage	24 V DC
Surge protection	Suppressor diode	max. admissible residual ripple at the input	100 mVpp

Output

Connection system	PUSH IN	Surge protection	Suppressor diode
-------------------	---------	------------------	------------------

General data

Conformal coating	Yes	
Control inputs	Reset	
MTTF	According to Standard	SN 29500
	Operating time (hours), min.	3,996,000 h
	Ambient temperature	40 °C
	Input voltage	24 V
	Duty cycle	100 %
Power loss, idling	384 mW	
Power loss, nominal load	500 mW	
Protection degree	IP20	
Surge voltage category	III	

Insulation coordination

Surge voltage category	III
------------------------	-----

Connection data (input)

Conductor cross-section, AWG/kcmil , max.	6 AWG	Conductor cross-section, AWG/kcmil , min.	18 AWG
Conductor cross-section, flexible , min.	0.75 mm ²	Conductor cross-section, rigid , max.	10 mm ²
Conductor cross-section, rigid , min.	0.75 mm ²	Connection system	PUSH IN
Number of terminals	2 (+,-)	Screwdriver blade	1.2 x 6.5
Wire connection cross section, flexible (input), max.	16 mm ²		

AMG FIM-C EX

Weidmüller Interface GmbH & Co. KG
 Klingenbergstraße 26
 D-32758 Detmold
 Germany

www.weidmueller.com

Technical data

Connection data (output)

Conductor cross-section, AWG/kcmil , max.	12 AWG	Conductor cross-section, AWG/kcmil , min.	26 AWG
Conductor cross-section, flexible , max.	1.5 mm ²	Conductor cross-section, flexible , min.	0.14 mm ²
Conductor cross-section, rigid , max.	1.5 mm ²	Conductor cross-section, rigid , min.	0.14 mm ²
Connection system	PUSH IN	Number of terminals	2 (I</ Alarm)
Screwdriver blade	0.4 x 2.5		

Connection data (signal)

Wire connection cross-section, flexible (signal), max.	1.5 mm ²
--	---------------------

Signalling

LED green	Operating voltage OK	Red LED	Alarm
Transistor output, positive-switching	Alarm	Yellow LED	External reset is signalled, Alarm is signalled

Approbations

Certificate No. (ATEX)	DEMKO17ATEX1870X	Certificate no. (cULus)	E258476
Certificate no. (cULusEX)	E470829	Institute (cULus)	CULUS
Institute (cULusEX)	CULUSEX	Institute(ATEX)	DEMKOATEX

Classifications

ETIM 6.0	EC000897	ETIM 7.0	EC000897
ETIM 8.0	EC000897	ETIM 9.0	EC000897
ECLASS 9.0	27-14-11-20	ECLASS 9.1	27-14-11-20
ECLASS 10.0	27-14-11-20	ECLASS 11.0	27-14-11-20
ECLASS 12.0	27-14-11-20	ECLASS 13.0	27-25-01-01

Environmental Product Compliance

REACH SVHC	Lead 7439-92-1
SCIP	a7fff16c-85aa-4fb0-a206-7be03f41b0b7

AMG FIM-C EX

Weidmüller Interface GmbH & Co. KG
 Klingenbergstraße 26
 D-32758 Detmold
 Germany

www.weidmueller.com

Technical data

Approvals

Approvals



ROHS	Conform
UL File Number Search	UL Website
Certificate no. (cULus)	E258476
Certificate no. (cULusEX)	E470829

Downloads

Approval/Certificate/Document of Conformity	MaxGuard AMG ELM UL 508 CSA C22.2.pdf MaxGuard EX ATEX .pdf BV Certificate DNV Certificate ABS Certificate RINA Certificate Declaration of Conformity UK Conformity Assessed
Engineering Data	CAD data – STEP
User Documentation	Manual_maxGUARD Operating instructions
Catalogues	Catalogues in PDF-format

AMG FIM-C EX

Weidmüller Interface GmbH & Co. KG
Klingenbergstraße 26
D-32758 Detmold
Germany

www.weidmueller.com

Drawings

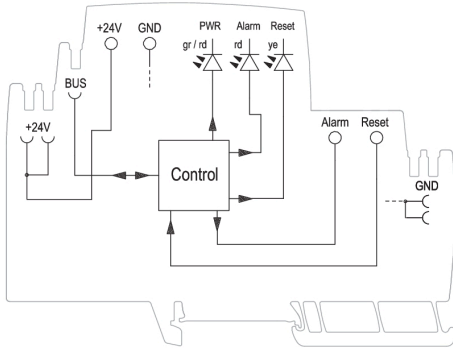

Schematic circuit diagram