

# HC-M-B16-MFH-B - Module carrier frame

1182090

<https://www.phoenixcontact.com/gb/products/1182090>

Please be informed that the data shown in this PDF document is generated from our online catalog. Please find the complete data in the user documentation. Our general terms of use for downloads are valid.

---

Module carrier frame, size: B16, type : for the panel mounting side (a, b, c, ...), 4 mm<sup>2</sup> ... 6 mm<sup>2</sup>,  
application: Module carrier frame



# HC-M-B16-MFH-B - Module carrier frame



1182090

<https://www.phoenixcontact.com/gb/products/1182090>

## Technical data

### Notes

General	This product replaces 1417400 HC-M-B16-MF-B
---------	---

### Product properties

Product type	Module carrier frame
Series	HC-M-B
	HC-M-02
	HC-M-03
	HC-M-03/04
	HC-M-04
	HC-M-05
	HC-M-06
	HC-M-08
	HC-M-08-GBIT
	HC-M-12
	HC-M-17
	HC-M-20
	HC-M-25
	HC-M-DSUB
	HC-M-EMV
	HC-M-HV
HC-M-HS	
HC-M-00	
Application	Module carrier frame
Type	B16
	B32
Number of module slots	4
Type	for the panel mounting side (a, b, c, ...)
Frame type	Module carrier frame

### Data management status

Article revision	03
------------------	----

### Connection data

#### Conductor connection

Conductor cross section	4 mm <sup>2</sup> ... 6 mm <sup>2</sup> (for PE conductor - power side)
	1 mm <sup>2</sup> ... 2.5 mm <sup>2</sup> (for PE conductor - control side)
Connection cross section AWG	12 ... 10 (for PE conductor - power side)
	18 ... 14 (for PE conductor - control side)
Tightening torque	0.5 Nm ... 0.8 Nm (Mounting screws for mounting in the HEAVYCON housing)

# HC-M-B16-MFH-B - Module carrier frame



1182090

<https://www.phoenixcontact.com/gb/products/1182090>

## Dimensions

Dimensional drawing	
Width	34.9 mm
Height	36 mm
Length	84.5 mm

## Material specifications

Contact carrier material	Die-cast zinc alloy
--------------------------	---------------------

## Mechanical properties

### Mechanical data

Insertion/withdrawal cycles	≥ 500
-----------------------------	-------

## Environmental and real-life conditions

### Ambient conditions

Ambient temperature (operation)	-40 °C ... 125 °C
---------------------------------	-------------------

## Mounting

Assembly note	<p>HC-MHR-PE16 ( 1636981) for PE connection extension to 16 mm<sup>2</sup>.</p> <p>Use wire end protection for PE wires (PE connection screws without wire protection) for housings without lateral connectors, max. thread length of the screw connection 12 mm</p> <p>When using the module carrier frame in metal housings, the connection of the PE conductor must be ensured via the PE connection provided on the module carrier frame or via a special metal PE module</p>
---------------	---

# HC-M-B16-MFH-B - Module carrier frame

1182090

<https://www.phoenixcontact.com/gb/products/1182090>

## Drawings

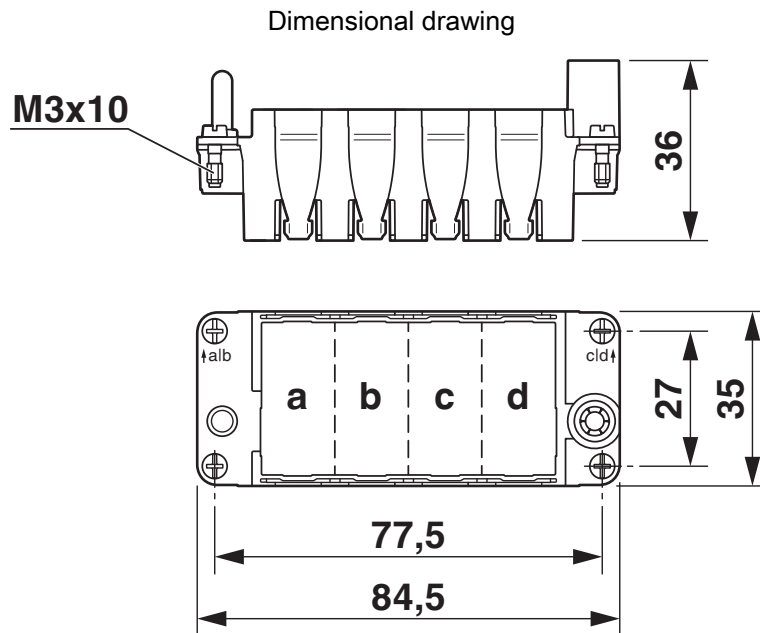

Dimensional drawing

# HC-M-B16-MFH-B - Module carrier frame



1182090

<https://www.phoenixcontact.com/gb/products/1182090>

## Approvals

To download certificates, visit the product detail page: <https://www.phoenixcontact.com/gb/products/1182090>

 **CSA**  
Approval ID: 13631

 **UL Recognized**  
Approval ID: E118976

 **UL Recognized**  
Approval ID: E118976

# HC-M-B16-MFH-B - Module carrier frame



1182090

<https://www.phoenixcontact.com/gb/products/1182090>

## Classifications

### ECLASS

ECLASS-11.0	27440206
ECLASS-12.0	27440206
ECLASS-13.0	27440206

### ETIM

ETIM 9.0	EC002312
----------	----------

### UNSPSC

UNSPSC 21.0	31261500
-------------	----------

1182090

<https://www.phoenixcontact.com/gb/products/1182090>

## Environmental product compliance

### EU RoHS

Fulfills EU RoHS substance requirements	Yes
Exemption	6(c)

### China RoHS

Environment friendly use period (EFUP)	EFUP-50
	An article-related China RoHS declaration table can be found in the download area for the respective article under "Manufacturer declaration". For all articles with EFUP-E, no China RoHS declaration table issued and required.

### EU REACH SVHC

REACH candidate substance (CAS No.)	Lead(CAS: 7439-92-1)
SCIP	c1b4b9a7-09d8-422a-a53d-de8db0f0f039

Phoenix Contact 2024 © - all rights reserved

<https://www.phoenixcontact.com>

PHOENIX CONTACT Ltd  
Halesfield 13, Telford  
Shropshire, TF7 4PG  
01952 681700  
[info@phoenixcontact.co.uk](mailto:info@phoenixcontact.co.uk)