



► PIT m4SEU

PILZ

THE SPIRIT OF SAFETY

Operating Manual-1004648-EN-08

- Control and signal devices



This document is the original document.

Where unavoidable, for reasons of readability, the masculine form has been selected when formulating this document. We do assure you that all persons are regarded without discrimination and on an equal basis.

All rights to this documentation are reserved by Pilz GmbH & Co. KG. Copies may be made for the user's internal purposes. Suggestions and comments for improving this documentation will be gratefully received.

Pilz®, PIT®, PMI®, PNOZ®, Primo®, PSEN®, PSS®, PVIS®, SafetyBUS p®, SafetyEYE®, SafetyNET p®, the spirit of safety® are registered and protected trademarks of Pilz GmbH & Co. KG in some countries.



SD means Secure Digital

| | | |
|----------|--|-----------|
| 1 | Introduction | 5 |
| 1.1 | Validity of documentation | 5 |
| 1.2 | Using the documentation | 5 |
| 1.3 | Definition of symbols | 5 |
| 2 | Overview | 7 |
| 2.1 | Device features | 8 |
| 2.2 | Device view | 9 |
| 3 | Safety | 11 |
| 3.1 | Intended use | 11 |
| 3.2 | Safety regulations | 12 |
| 3.2.1 | Use of qualified personnel | 12 |
| 3.2.2 | Warranty and liability | 13 |
| 3.2.3 | Disposal | 13 |
| 4 | Security | 14 |
| 5 | Function description | 15 |
| 5.1 | Permissions | 17 |
| 5.2 | Inputs and signal outputs for operating mode selection or operating mode interface | 17 |
| 5.3 | Configuration of functions | 18 |
| 5.4 | Operating mode interface | 21 |
| 5.4.1 | Switching behaviour after permission is removed | 21 |
| 5.4.2 | Control program requirements | 21 |
| 5.5 | Interface for status information | 22 |
| 5.5.1 | Timing diagrams | 24 |
| 5.5.1.1 | Operator actions | 24 |
| 5.5.1.2 | Device error | 26 |
| 5.5.1.3 | Application error: "No authorisation" | 26 |
| 5.5.1.4 | Application error: "Pushbutton operated incorrectly" | 28 |
| 5.6 | Key ID interface | 30 |
| 5.6.1 | Key ID number (serial number) of transponder | 30 |
| 5.6.2 | Communication mode for downloading the Key ID number | 31 |
| 5.6.2.1 | Transmitter-controlled communication mode | 32 |
| 5.6.2.2 | Handshake-controlled communication mode | 32 |
| 5.6.2.3 | Advanced communication mode | 33 |
| 5.6.3 | Evaluation by a controller | 34 |
| 5.6.3.1 | Evaluation of the Key ID number with transmitter-controlled communication | 34 |
| 5.6.3.2 | Evaluation of the Key ID number with handshake-controlled communication | 37 |
| 5.6.3.3 | Evaluation of the Key ID number with advanced communication | 41 |
| 5.7 | PITreader interface | 41 |
| 5.8 | Operating mode lock and operating mode preselection | 41 |
| 5.8.1 | Operating mode lock | 41 |
| 5.8.2 | Operating mode preselection | 43 |
| 6 | Installation | 46 |
| 6.1 | General installation guidelines | 46 |

| | | |
|-----------|--|-----------|
| 6.2 | Dimensions in mm..... | 46 |
| 7 | Wiring | 48 |
| 7.1 | Terminal configuration..... | 48 |
| 7.2 | Connecting the unit | 49 |
| 7.3 | Connection to a controller | 50 |
| 8 | Operation | 54 |
| 8.1 | Select operating modes 1 ... 4 | 55 |
| 8.2 | Select special mode (service) | 56 |
| 8.3 | Monitoring of operating time..... | 57 |
| 8.4 | Switchover time..... | 57 |
| 8.5 | Device status display | 57 |
| 8.6 | Troubleshooting | 58 |
| 8.6.1 | Delete error | 58 |
| 8.7 | Diagnostics..... | 58 |
| 8.7.1 | Status information about the interface for status information..... | 58 |
| 8.7.2 | Status information about the signal outputs O1 ... O4 | 59 |
| 9 | Technical details | 61 |
| 9.1 | Safety characteristic data..... | 63 |
| 10 | Order reference | 66 |
| 10.1 | Product..... | 66 |
| 10.2 | Accessories..... | 66 |
| 10.2.1 | Authentication system PITreader Key..... | 66 |
| 10.2.2 | Authentication system PITreader Card | 66 |
| 11 | EC declaration of conformity | 67 |
| 12 | UKCA-Declaration of Conformity | 68 |

1 Introduction

1.1 Validity of documentation

This documentation is valid for the product PIT m4SEU. It is valid until new documentation is published.

This operating manual explains the function and operation, describes the installation and provides guidelines on how to connect the product.

1.2 Using the documentation

This document is intended for instruction. Only install and commission the product if you have read and understood this document. The document should be retained for future reference.

1.3 Definition of symbols

Information that is particularly important is identified as follows:



DANGER!

This warning must be heeded! It warns of a hazardous situation that poses an immediate threat of serious injury and death and indicates preventive measures that can be taken.



WARNING!

This warning must be heeded! It warns of a hazardous situation that could lead to serious injury and death and indicates preventive measures that can be taken.



CAUTION!

This refers to a hazard that can lead to a less serious or minor injury plus material damage, and also provides information on preventive measures that can be taken.



NOTICE

This describes a situation in which the product or devices could be damaged and also provides information on preventive measures that can be taken. It also highlights areas within the text that are of particular importance.



INFORMATION

This gives advice on applications and provides information on special features.

2 Overview

The product may only be used in conjunction with the following external components:

- ▶ 24 VDC power supply for the supply voltage
- ▶ 1 authentication system PITreader (see [Order reference \[66\]](#)) to restrict access for operating mode selection
- ▶ Pushbutton for selecting the operating mode (one pushbutton per operating mode)
- ▶ Display elements for the operating mode (one display element per operating mode)
- ▶ Safety controller to activate the selected operating mode

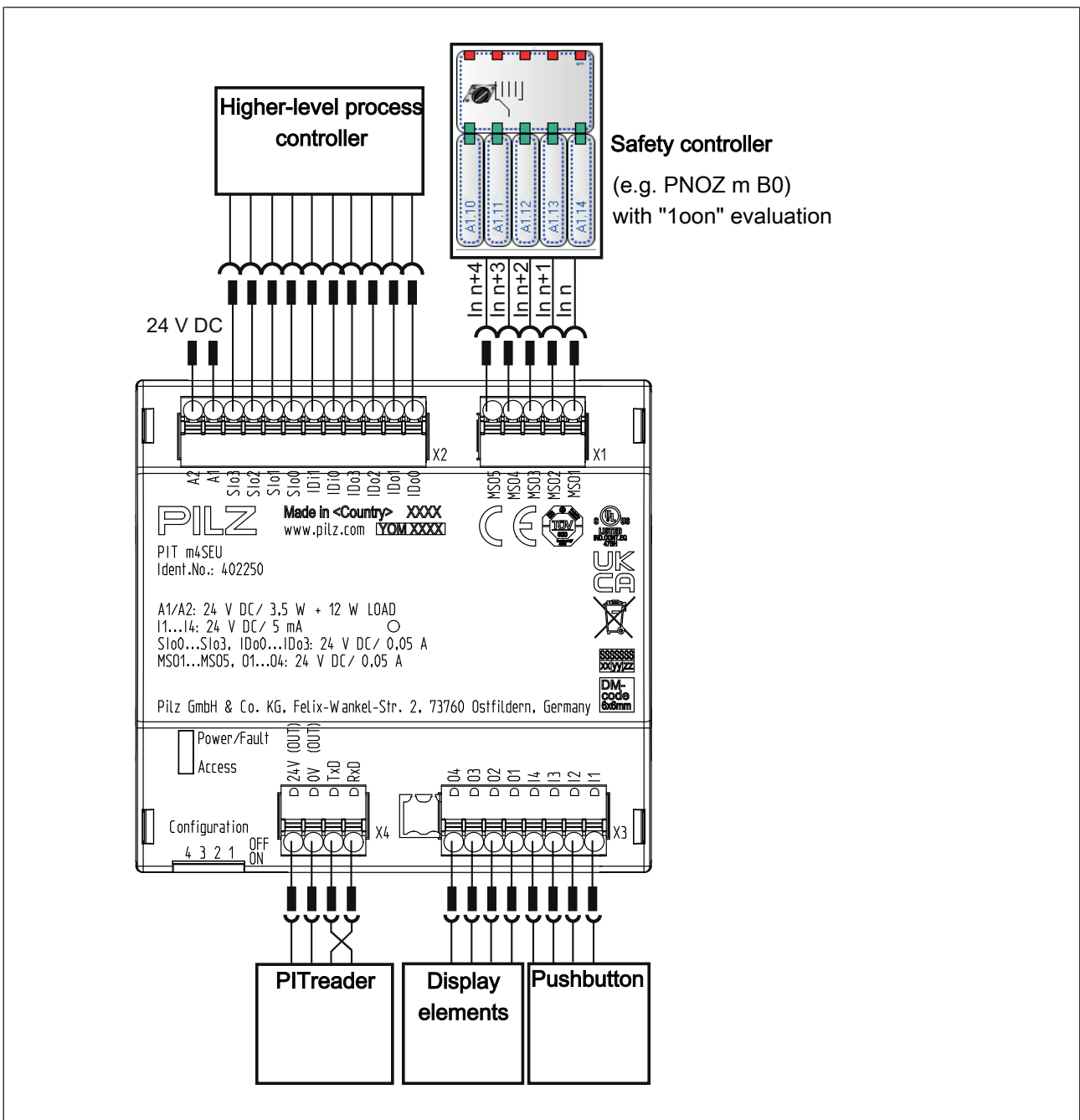





Fig.: PIT m4SEU in an application (principle)

2.1 Device features

The product has the following features:

- ▶ Supply voltage 24 VDC
- ▶ 4 operating modes 1 ... 4
- ▶ 1 special operating mode 5 (Service)
- ▶ 5 monitored semiconductor outputs (24 V) in accordance with EN 61496-1;
1 semiconductor output per operating mode
- ▶ 4 digital inputs (I1 ... I4) in accordance with EN 61131-2 type 3 for connecting external pushbuttons
- ▶ 4 outputs (O1 ... O4) for connecting external display elements
- ▶ Access to operating mode selection restricted via 1 authentication system PITreader
- ▶ Interface for status information, consisting of 4 signal outputs (24 V)
- ▶ Status information is divided into information classes:
 - Operator actions
 - Position transponder
 - Remove transponder
 - Select operating mode
 - Messages (e.g. application error, malfunction)
- ▶ Interface (Key ID interface) for downloading the Key ID number of the transponder you are using, consisting of
 - 3 semiconductor outputs (24 V)
 - 2 inputs
 - 1 configurable input/output
can be configured as
 - input (see [Transmitter-controlled](#)  32] and [Handshake-controlled communication mode](#)  32])
 - output (see [Advanced communication mode](#)  33])
- ▶ Configurable communication mode for downloading the Key ID number
 - Transmitter-controlled communication mode
 - Handshake-controlled communication mode
 - Advanced communication mode

2.2 Device view

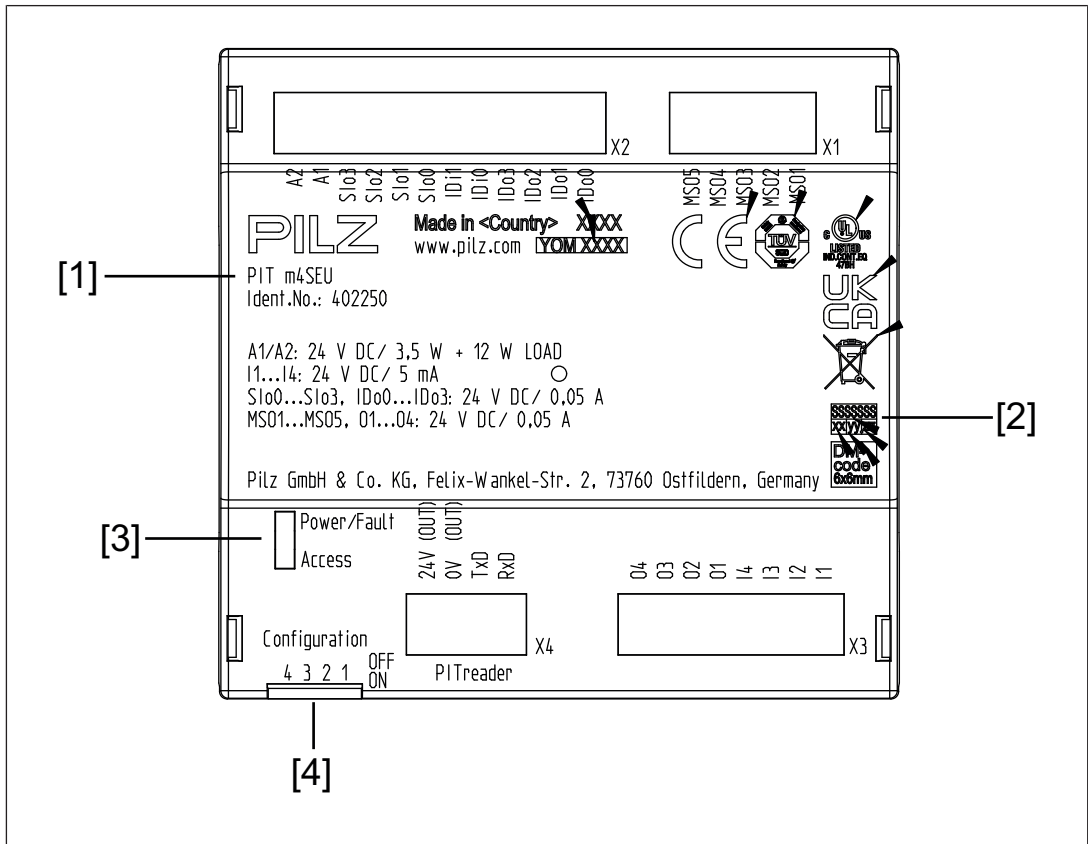

Fig.: Front view

Legend

- X1 Operating mode interface MS01 ... MS05
- X2 Supply voltage A1, A2
Interface for status information Slo0 ... Slo3
Key ID interface IDo0 ... IDo3 and IDi0 ... IDi1
- X3 Inputs I1 ... I4
Outputs O1 ... O4
- X4 PITreader interface
- [1] Device name and order number
- [2] Serial number
- [3] LEDs
- [4] DIP switch for configuring the switching behaviour and configuring the communication mode for downloading the Key ID number

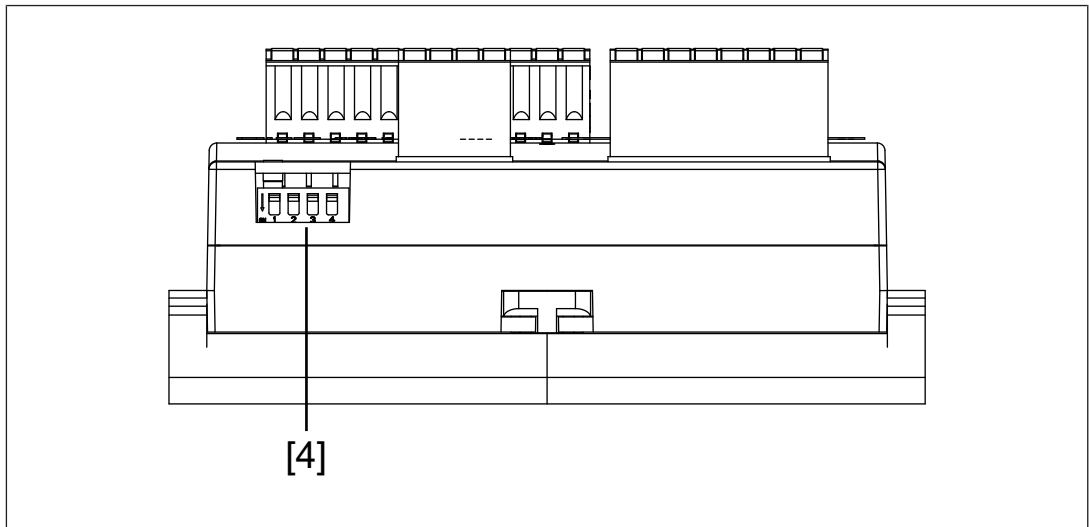

Fig.: Side view

Legend

- [4] DIP switch for configuring the switching behaviour and configuring the communication mode for downloading the Key ID number

3 Safety

3.1 Intended use

The PIT m4SEU is suitable for machines that can be operated in multiple operating modes with different safety functions and/or work procedures. It enables you to switch between defined operating modes, such as:

- ▶ Set-up mode
- ▶ Manual mode
- ▶ Automatic mode
- ▶ Service

The PIT m4SEU meets the following safety requirements:

1. Safety-related selection and switching of an operating mode
 - Prevents unintentional switching
The switch to a different operating mode is only recognised once the corresponding (selection) pushbutton has been operated for a defined period ("deliberate operator action"). Multiple operation of (selection) pushbuttons is detected.
 - Safe "1oon" circuit for the operating mode outputs
The PIT m4SEU only ever leads to one operating mode output "1" signal.
2. Safety-related switching-on of the operating mode after power-on
In the event of a cold start, the device will either be in operating mode 1 or in the most recently selected operating mode, depending on the device configuration (see also [Configuration of functions](#) [18]).

The following access restriction requirements (security functions) for operating mode selection are met with the accessory device PITreader:

- ▶ Interlock to protect against unauthorised switching
To switch to an operating mode with the (selection) pushbutton, a transponder must be positioned in the read area of the PITreader.
- ▶ Access permissions are restricted to certain groups
A transponder with the relevant permission is required in order to switch to a certain operating mode.

Depending on the application area and its respective regulations, the device can be used up to SIL 2 (EN IEC 61508) and up to PL d (EN ISO 13849-1), if the operating modes are evaluated by a safety controller with safe "1oon" evaluation. The operating mode is activated (machine operation changed) via the control program on a safety controller.



NOTICE

The provisions of the type C standards (machinery safety standards) for the respective application must be observed with regard to operating mode selection, as described in section 5.2.4 of EN ISO 16090-1 for example.

**NOTICE**

Faulty operation of the PIT m4SEU can lead to hazardous situations. Switching to an operating mode must not initiate a hazardous movement, nor may it cancel an existing control command.

In the event of an error that can lead to the loss of one of the safety functions, the PIT m4SEU switches to a safe state and the operating mode that is currently selected is maintained. The only way to return from the safe state is to switch the PIT m4SEU off and then on again.

Improper use

The following is deemed improper use in particular:

- ▶ Any component, technical or electrical modification to the product,
- ▶ Use of the product outside the areas described in this operating manual,
- ▶ Use of the product outside the technical details (see chapter entitled [Technical Details](#)  61).

**NOTICE****EMC-compliant electrical installation**

The product is designed for use in an industrial environment. The product may cause interference if installed in other environments. If installed in other environments, measures should be taken to comply with the applicable standards and directives for the respective installation site with regard to interference.

3.2 Safety regulations

3.2.1 Use of qualified personnel

The products may only be assembled, installed, programmed, commissioned, operated, de-commissioned and maintained by persons who are competent to do so.

A competent person is a qualified and knowledgeable person who, because of their training, experience and current professional activity, has the specialist knowledge required. In order to inspect, assess and handle products, devices, systems, plant and machinery, this person must be familiar with the state of the art and the applicable national, European and international laws, directives and standards.

It is the company's responsibility only to employ personnel who

- ▶ Are familiar with the basic regulations concerning health and safety / accident prevention,
- ▶ Have read and understood the information provided in the section entitled Safety
- ▶ Have a good knowledge of the generic and specialist standards applicable to the specific application.

3.2.2 **Warranty and liability**

All claims to warranty and liability will be rendered invalid if

- ▶ The product was used contrary to the purpose for which it is intended,
- ▶ Damage can be attributed to not having followed the guidelines in the manual,
- ▶ Operating personnel are not suitably qualified,
- ▶ Any type of modification has been made (e.g. exchanging components on the PCB boards, soldering work etc.).

3.2.3 **Disposal**

- ▶ In safety-related applications, please comply with the mission time T_M stated in the safety-related characteristic data.
- ▶ When decommissioning, please comply with local regulations regarding the disposal of electronic devices (e.g. Electrical and Electronic Equipment Act).

4 Security

To secure plants, systems, machines and networks against cyberthreats it is necessary to implement (and continuously maintain) an overall industrial security concept that is state of the art.

Perform a risk assessment in accordance with VDI/VDE 2182 or IEC 62443-3-2 and plan the security measures with care. If necessary, seek advice from Pilz Customer Support.

- ▶ The product is not protected against physical manipulation. For this reason, both the product and the authentication system PITreader, including the cable between the two devices, should be installed in a lockable control cabinet.
- ▶ The configuration computer that accesses the product has to be protected from attacks by a firewall or other suitable measures. We recommend that a virus scanner is used on this configuration computer and updated regularly.
- ▶ If necessary, protect the configuration computer and the product from unauthorised use by assigning passwords and taking further measures if required. We also recommend that the user logged on to this configuration computer does not have administrator rights.
- ▶ Only assign strong passwords and handle the passwords carefully. Be guided by generally accepted guidelines such as NIST 800-63b for example.
- ▶ Assign different permissions for the various user groups (e.g. diagnostics - configuration).
- ▶ As soon as possible, install firmware updates that Pilz provides for the product.
- ▶ Check the log of the product for security-relevant entries on a regular basis.
- ▶ Before disposal, the product must be safely decommissioned. To do this, all the data must be deleted from the device.
 - Set the configuration back to its default settings or delete the configuration.
 - Switch off the product.
 - If the product includes a removable data medium, remove it and format it at the computer. Do not carry out a quick formatting. Alternatively, you can use a program to safely delete data or destroy the memory mechanically.

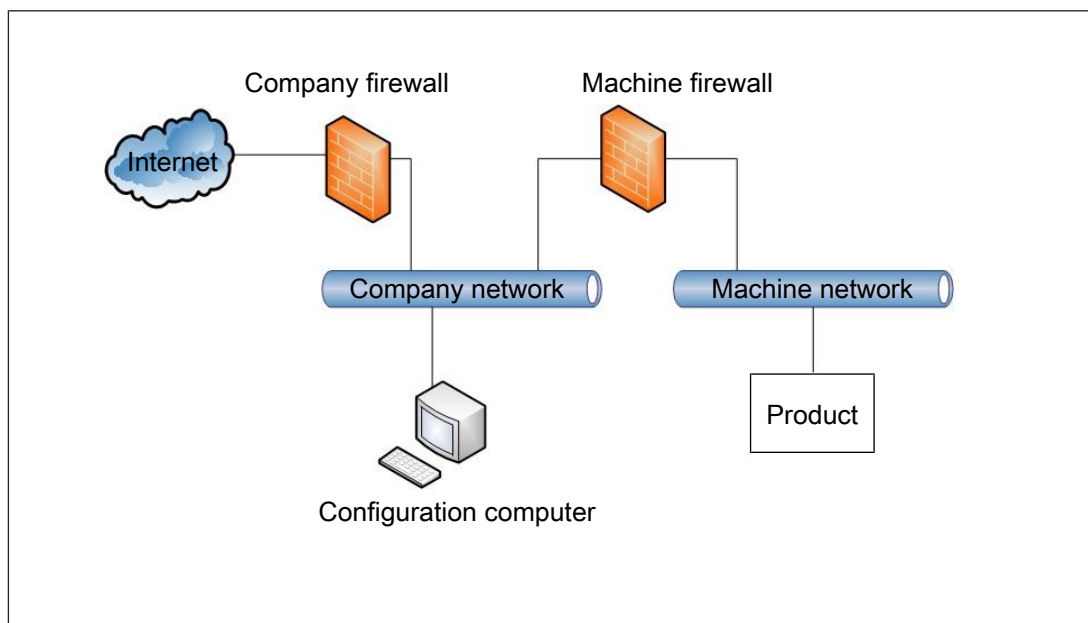

Fig.: Example network topology

5 Function description

The device enables you to switch between 5 different operating modes (operating modes 1 ... 4 and special operating mode 5 (Service)) and enables access restriction via 1 authentication system PITreader.

4 inputs are available for operating mode 1 ... 4, for connecting external pushbuttons. For special operating mode 5 (Service), the pushbutton for operating mode 1 must be operated for a certain period (see [Monitoring of operating time](#) [📖 57]). Each input (pushbutton) is assigned a monitored semiconductor output (see [Operating mode interface](#) [📖 21]). Operating the pushbutton switches the semiconductor output from a "0" signal to a "1" signal. The device guarantees that only one of the semiconductor outputs has a "1" signal at any one time.



INFORMATION

Storage of operating mode

When configured with operating mode storage (see [Configuration of functions](#) [📖 18]), after a restart the unit will start with the last selected operating mode.

If operating mode storage is **not** configured, the device will always start with operating mode 1. For this reason, make sure that operating mode 1 is the safest operating mode.

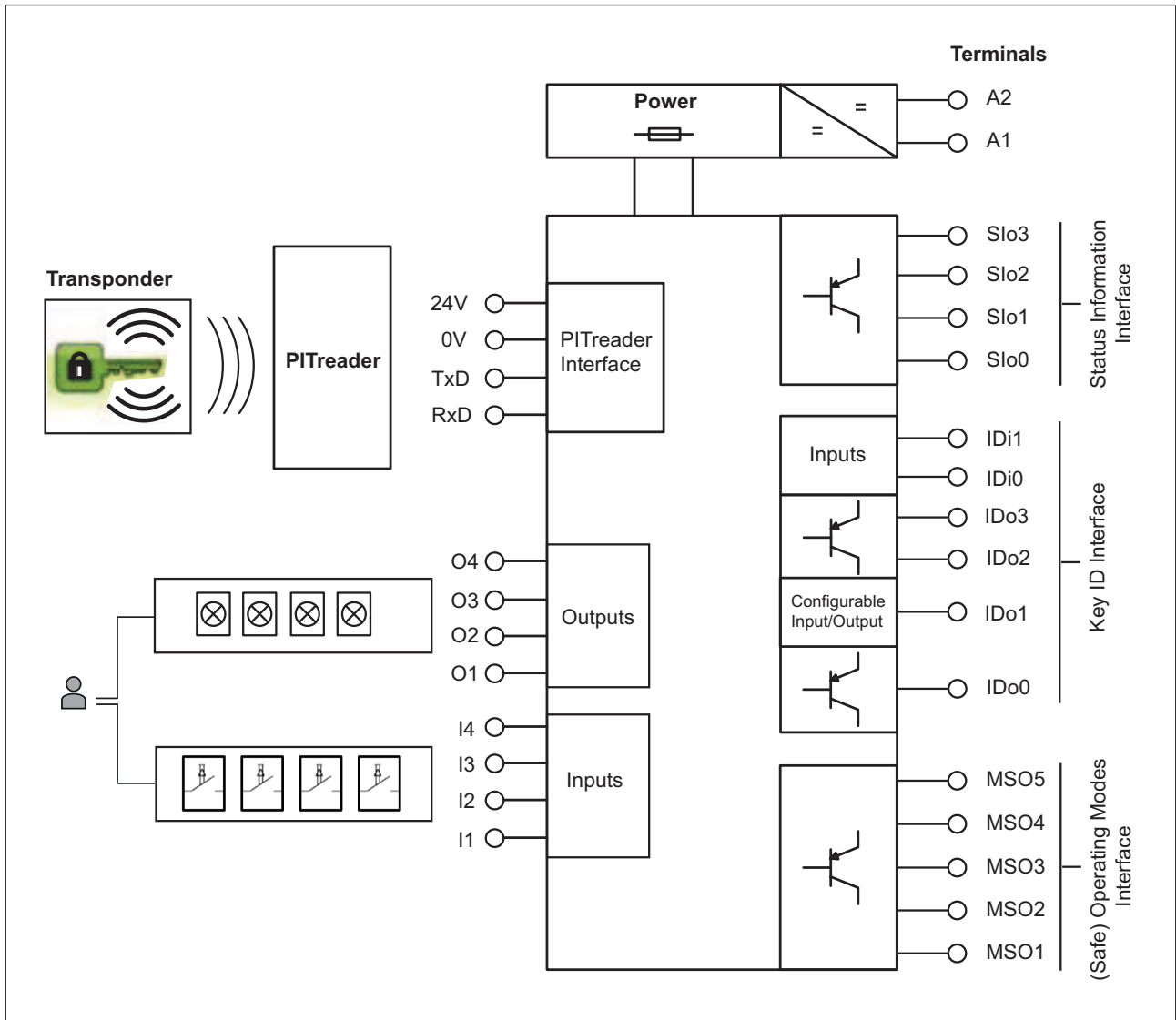

Fig.: Block diagram

Legend

- Transponder Transponder to enable a change of operating mode
- PITreader Authentication system
- PITreader Interface Interface for connecting the PITreader, for permission 0V, 24V, TxD, RxD to select the operating mode
- I1 ... I4 Inputs for connecting external pushbuttons to select the operating mode
- O1 ... O4 Operating mode outputs for connecting external display elements
- A1, A2 Supply voltage
- MSO1 ... MSO5 Operating mode interface
Interface for displaying the operating mode that is currently selected, consisting of 5 monitored outputs

- IDo0 ... IDo3 and IDi0 ... IDi1 Key ID interface
Interface for downloading the Key ID number to a controller, consisting of 3 outputs, 2 inputs and 1 configurable input/output
- Slo0 ... Slo3 Interface for status information
Interface for signalling status information, consisting of 4 signal outputs

The PIT m4SEU is protected against unauthorised operation. A switch between operating modes must be enabled via a transponder on the PITreader.

5.1 Permissions

| Permission | Permission for operating mode |
|------------|---|
| 1 | Operating mode 1 |
| 2 | Operating mode 1 and 2 |
| 3 | Operating mode 1, 2 and 3 |
| 4 | Operating mode 1, 2, 3 and 4 |
| 5 | Operating mode 1, 2, 3, 4 and 5 (Service) |

Further information on permissions and transponders is available in the PITreader operating manual.



INFORMATION

Only the transponder permissions 1-5, which are detected by the authentication system PITreader, enable operating mode selection on the PIT m4SEU. All other permissions are locked on the PIT m4SEU.

5.2 Inputs and signal outputs for operating mode selection or operating mode interface

- ▶ 4 digital inputs type 3 in accordance with EN 61131-2 are available for connecting external pushbuttons.
Features:
 - Safe inputs with "1oon" evaluation and time monitoring. Faulty operations are detected and rejected without error message.
 - For further features see Technical details.
- ▶ 4 signal outputs (O1 ... O4) are available for connecting display elements. The selected operating mode is displayed via a 1-signal at the signal output.
Features:
 - No bridging of supply interruptions.
 - For further features see Technical details.

► Allocation of signal outputs to inputs:



| Pushbutton | Input | Signal output |
|--------------------|-------|---------------|
| Operating mode 1/5 | I1 | O1 |
| Operating mode 2 | I2 | O2 |
| Operating mode 3 | I3 | O3 |
| Operating mode 4 | I4 | O4 |

5.3 Configuration of functions

The PIT m4SEU has a DIP switch, which you can use to set the required communication mode for downloading the Key ID number and the device's switching behaviour

- after the transponder is removed and
- after the voltage reset

The communication modes have different functions. These functions are described in the following subsections:

- [Transmitter-controlled communication mode](#)  32]
- [Handshake-controlled communication mode](#)  32]
- [Advanced communication mode](#)  33]





NOTICE











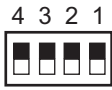





It is essential to note:

- The configuration may only be performed by a competent person.
- The configuration must be performed when the supply voltage is switched off.
- The configuration is adopted as the device is started up, provided the switch setting is valid. If not, the device switches to a "Device error" fault condition.
- During operation, the DIP switch setting is monitored for any change. If the switch setting is changed during operation, the device switches to a "Device error" fault condition, remedy: [Delete error](#)  58].
- The communication mode changes when you change the DIP switch setting from Pos. [D1]-[D4] to Pos. [D5]-[D8]. In this case you automatically switch to advanced communication mode.

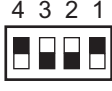
Legend

| | |
|---|----------------------------|
|  | DIP switch in OFF position |
|  | DIP switch in ON position |

The sliders of the DIP switches are shown in black in the table.

| DIP switch setting | Switching behaviour of operating mode | Communication modes | Operating mode lock and operating mode preselection |
|--|---|--|---|
| [D1]: Default setting Off  On  | Operating mode 1-4: Operating mode retention | Transmitter or handshake-controlled communication mode | <input type="checkbox"/> |
| | Operating mode 5: Service fallback | | |
| [D2] Off  On  | Operating mode retention | Transmitter or handshake-controlled communication mode | <input type="checkbox"/> |
| [D3] Off  On  | Operating mode fallback | Transmitter or handshake-controlled communication mode | <input type="checkbox"/> |
| [D4] Off  On  | Operating mode storage | Transmitter or handshake-controlled communication mode | <input type="checkbox"/> |
| [D5] Off  On  | Operating mode 1-4: Operating mode retention | Advanced communication mode | <input checked="" type="checkbox"/> |
| | Operating mode 5: Service fallback | | |
| [D6] Off  On  | Operating mode retention | Advanced communication mode | <input checked="" type="checkbox"/> |
| [D7] Off  On  | Operating mode fallback | Advanced communication mode | <input checked="" type="checkbox"/> |
| [D8] Off  On  | Operating mode storage | Advanced communication mode | <input checked="" type="checkbox"/> |

DIP configuration



NOTICE

It is **essential** to note that only the DIP switch settings described above will be assessed as valid. With all other DIP switch settings, the device switches to a "Device error" fault condition.

Explanation of the switching behaviour

| | When the transponder is removed | After a voltage reset |
|--|--|---|
| Operating mode retention | <ul style="list-style-type: none"> ▶ the operating mode currently selected is retained, ▶ the assigned display element is lit or all the display elements flash (operating mode 5), ▶ the assigned semiconductor output has a "1" signal. | <ul style="list-style-type: none"> ▶ operating mode 1 is activated, ▶ display element 1 is lit, ▶ MSO1 has a "1" signal. |
| Operating mode fallback | <ul style="list-style-type: none"> ▶ the operating mode switches to 1, ▶ display element 1 is lit, ▶ MSO1 has a "1" signal. | <ul style="list-style-type: none"> ▶ operating mode 1 is activated, ▶ display element 1 is lit, ▶ MSO1 has a "1" signal. |
| Service fallback (operating mode 5 must be active) | <ul style="list-style-type: none"> ▶ the operating mode switches to 1, ▶ display element 1 is lit, ▶ MSO1 has a "1" signal. | <ul style="list-style-type: none"> ▶ operating mode 1 is activated, ▶ display element 1 is lit, ▶ MSO1 has a "1" signal. |
| Operating mode storage | <ul style="list-style-type: none"> ▶ the operating mode currently selected is retained, ▶ the assigned display element is lit or all the display elements flash (operating mode 5), ▶ the assigned semiconductor output has a "1" signal. | <ul style="list-style-type: none"> ▶ the operating mode selected most recently is activated, ▶ the assigned display element is lit or all the display elements flash (operating mode 5), ▶ the assigned semiconductor output has a "1" signal. |



NOTICE

Changing the operating mode to operating mode 1 by removing the transponder is **not** a safety-related function. Switching of the operating mode must be validated in accordance with the safety requirements.

5.4 Operating mode interface

The operating mode interface consists of the monitored outputs MSO1 ... MSO5 (see [Block diagram \[15\]](#)). The designation "MSO" stands for "mode of safe operation". Outputs are assigned inputs, which can be used to select an operating mode if they have the relevant permission (transponder):

| Input | Output | Operating mode | |
|-------|--------|------------------|--|
| I1 | MSO1 | Operating mode 1 | Operating mode 1/5 is selected based on the operating time of input 1 (see Monitoring of operating time [57]) |
| | MSO5 | Operating mode 5 | |
| I2 | MSO2 | Operating mode 2 | |
| I3 | MSO3 | Operating mode 3 | |
| I4 | MSO4 | Operating mode 4 | |

5.4.1 Switching behaviour after permission is removed

If permission is removed after changing to a different operating mode, it is possible to configure the subsequent switching behaviour of MSO1 ... MSO5. A DIP switch is available for this purpose (see [Control elements \[9\]](#)).

The individual switch settings and the resulting switching behaviour are described in the chapter entitled [Configuration of functions \[18\]](#).

5.4.2 Control program requirements

In order to achieve SIL 2 (EN IEC 61508)/PL d (EN ISO 13849-1) in an application, the evaluation must be carried out by a safety-related function block. The safety-related function block must meet the following requirements:

- ▶ The function block must enable safe "1oon" evaluation of the output signals at MSO1 ... MSO5.
- ▶ If two or more operating modes are present at the same time, this must be detected as an error.



INFORMATION

At the moment the device is switched on and during the switchover time t_1 , the function block must bridge a "0" signal at all outputs on the operating mode interface (see [Switchover time \$t_1\$ \[57\]](#)).

If a Pilz safety controller (e.g. PNOZ m1p) is used in conjunction with an "operating mode selector switch" function element, then this requirement is met automatically.

5.5 Interface for status information

Various status information can be signalled via the interface for status information (see [Block diagram \[15\]](#)). The status information can be evaluated through a controller.

The status information is subdivided into the following information classes:

- ▶ Operator actions
 - Position transponder
 - Remove transponder
 - Select operating mode
- ▶ Messages (e.g. application error, malfunction, response)



NOTICE

When the operating mode is selected (Slo0 ... Slo3 = 3h, 8h ... Bh) and when there is a device error (Dh), the information remains present indefinitely. All other information stays active for just **200 ms**. After that time the selected operating mode is again displayed.

| Status information | Information class | Slo3 (MSB) | Slo2 | Slo1 | Slo0 (LSB) | Value (in Hex) |
|---|-------------------|------------|------|------|------------|----------------|
| Operating mode preselection is switched [5] | Response | 0 | 0 | 0 | 0 | 0h |
| Reserve | - - - | 0 | 0 | 0 | 1 | 1h |
| Transponder 5 – Positioned [1] | Operator action | 0 | 0 | 1 | 0 | 2h |
| Operating mode 5 selected | Operator action | 0 | 0 | 1 | 1 | 3h |
| Transponder 1 – Positioned [1] | Operator action | 0 | 1 | 0 | 0 | 4h |
| Transponder 2 – Positioned [1] | Operator action | 0 | 1 | 0 | 1 | 5h |
| Transponder 3 – Positioned [1] | Operator action | 0 | 1 | 1 | 0 | 6h |
| Transponder 4 – Positioned [1] | Operator action | 0 | 1 | 1 | 1 | 7h |
| Operating mode 1 selected | Operator action | 1 | 0 | 0 | 0 | 8h |
| Operating mode 2 selected | Operator action | 1 | 0 | 0 | 1 | 9h |
| Operating mode 3 selected | Operator action | 1 | 0 | 1 | 0 | Ah |
| Operating mode 4 selected | Operator action | 1 | 0 | 1 | 1 | Bh |
| No permission [2] | Application error | 1 | 1 | 0 | 0 | Ch |
| Device error [3] | Error | 1 | 1 | 0 | 1 | Dh |
| Pushbutton operated incorrectly [4] | Application error | 1 | 1 | 1 | 0 | Eh |
| Remove transponder | Operator action | 1 | 1 | 1 | 1 | Fh |

[1] When a pushbutton is released, information as to which transponder is used will be displayed for 200 ms (see Status information 2h and 4h ... 7h). The selected operating mode is then displayed (see Status information 3h and 8h ... Bh).

Please refer to the timing diagrams for [Operator actions](#)  24].

[2] The error "No permission" (Ch) is registered in the following cases:

- ▶ Operating mode selection without transponder
- ▶ Operating mode selection with a transponder that does not have permission for the selected operating mode
- ▶ Use of a transponder that does not have permission for the active operating mode
- ▶ Transponder not positioned in time before the operating mode is selected
- ▶ A pushbutton is operated during the operating mode lock

The remedy is described in the section entitled [Troubleshooting](#)  58].

Please refer to the timing diagrams for [Application error: "No authorisation"](#)  26].

[3] A "Device error" (Dh) is registered,

- ▶ if the DIP switch setting is changed during operation (see [Delete error](#)  58]) or
- ▶ if one of the operating mode outputs MSO1 ... MSO5 is stuck because of external voltage (stuck-at-1 or stuck-at-0) or
- ▶ if there is an internal device error.

The remedy is described in the section entitled [Troubleshooting](#)  58].

[4] The error "Pushbutton operated incorrectly" (Eh) is displayed in the following cases:

- ▶ Multiple pushbuttons operated
- ▶ Pushbutton operated for too long (timeout for operating mode 1 to 4 = 5 s and timeout for operating mode 5 = 10 s)
Note: If a pushbutton is operated for < 50 ms this will not be evaluated, so there will be no reaction.
- ▶ Button was released after the transponder was removed

The remedy is described in the section entitled [Troubleshooting](#)  58].

Please refer to the timing diagrams for [Application error: "Pushbutton operated incorrectly"](#)  28].

[5] In configurations with DIP switch settings [5] ... [8], with operating mode preselection the switching of operating mode outputs to the preselected operating mode is displayed for 200 ms. This is used as a feedback for the controller.

5.5.1 Timing diagrams

5.5.1.1 Operator actions



The following timing diagrams show how status information is registered at outputs Slo0 ... Slo3, based on operator actions.



INFORMATION

The signal changes at the outputs without delay. Use a software filter to avoid read-in errors.

Key:

| | |
|---|---|
|  | Message is displayed constantly |
|  | Message is displayed briefly (200 ms) |
| MSO | Mode of safe operation (operating mode) |

Select operating mode

1. Start position:
 - Operating mode 1 is selected
 - DIP switch in default setting
2. Operator action: Position transponder in the read area of the PITreader (e.g. permission 2)
3. Operator action: Select operating mode (e.g. press pushbutton on input I2 for operating mode 2)
4. Operator action: Remove transponder

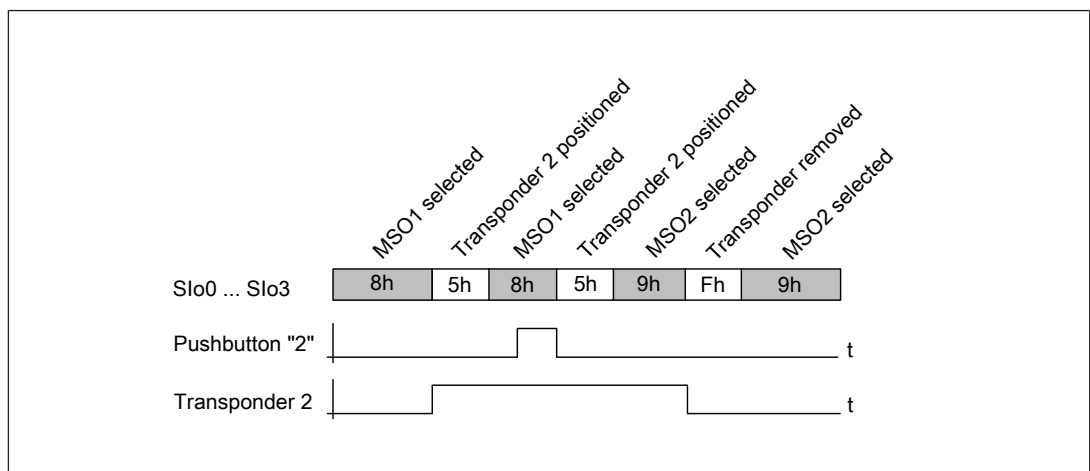

Fig.: Timing diagram for "Select operating mode" with DIP switch setting [D1] (default setting) and [D5]

Remove transponder

1. Start position:

⇒ Operating mode 5 is selected and the transponder with permission 5 is positioned in the read area of the PITreader

or

⇒ One of the operating modes 1 ... 4 is selected and a transponder with the relevant permission is positioned in the read area of the PITreader

2. Operator action: Remove transponder on the PITreader

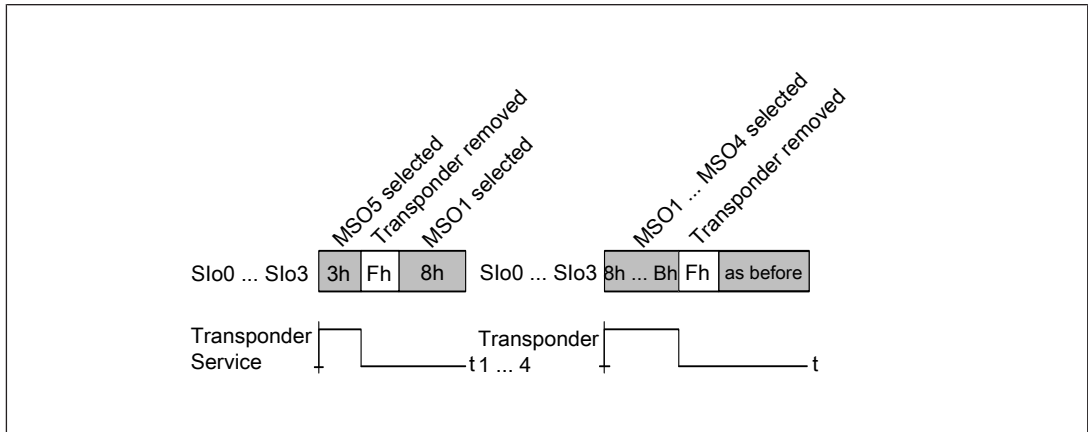

Fig.: Timing diagram for "Remove transponder" with DIP switch setting [D1] (default setting) and [D5]

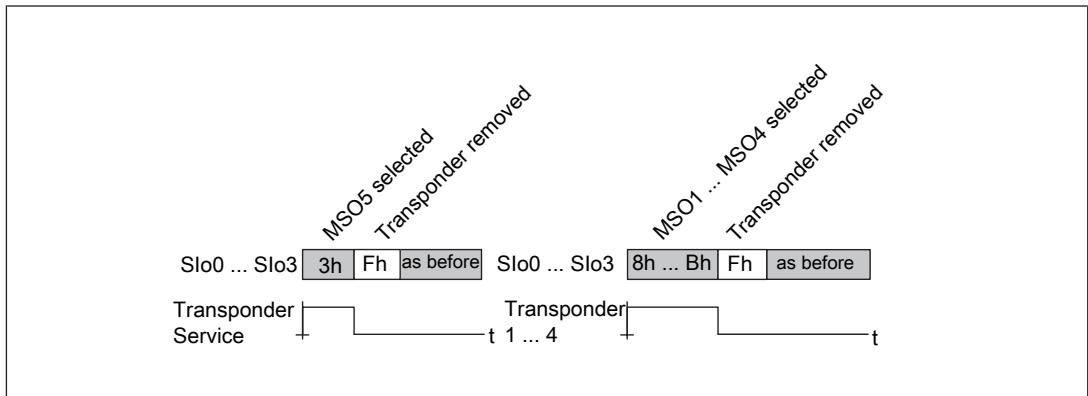

Fig.: Timing diagram for "Remove transponder" with DIP switch setting [D2], [D4], [D6] and [D8]

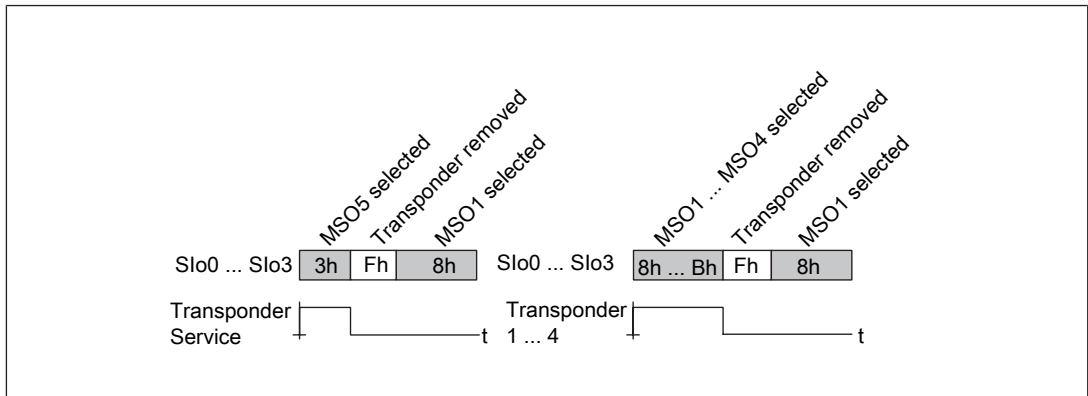



Fig.: Timing diagram for "Remove transponder" with DIP switch setting [D3] and [D7]

5.5.1.2

Device error

The following timing diagram shows how status information is registered at outputs Slo0 ... Slo3, based on a device error.

Key:

| | |
|--|---|
|  | Message is displayed constantly |
|  | Message is displayed briefly (200 ms) |
| MSO | Mode of safe operation (operating mode) |

Device error

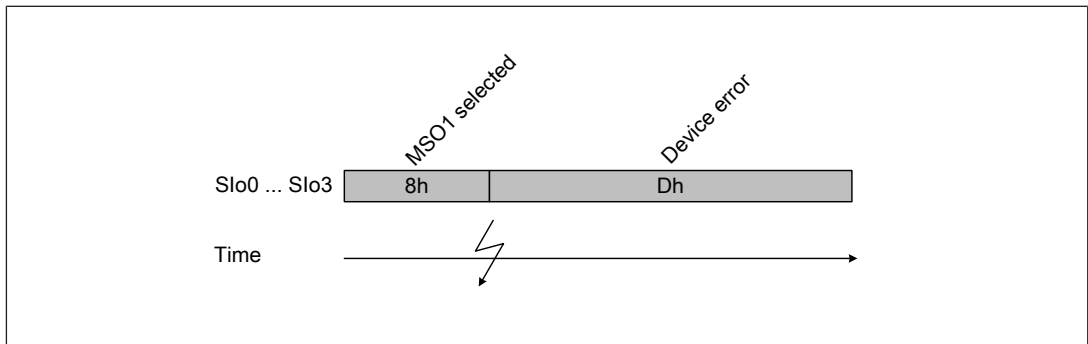



Fig.: Timing diagram for device error

5.5.1.3

Application error: "No authorisation"

The following timing diagrams show how status information is registered at outputs Slo0 ... Slo3, based on the application errors "No permission".

Key:

| | |
|---|---|
|  | Message is displayed constantly |
|  | Message is displayed briefly (200 ms) |
| MSO | Mode of safe operation (operating mode) |

Operating mode selection without transponder

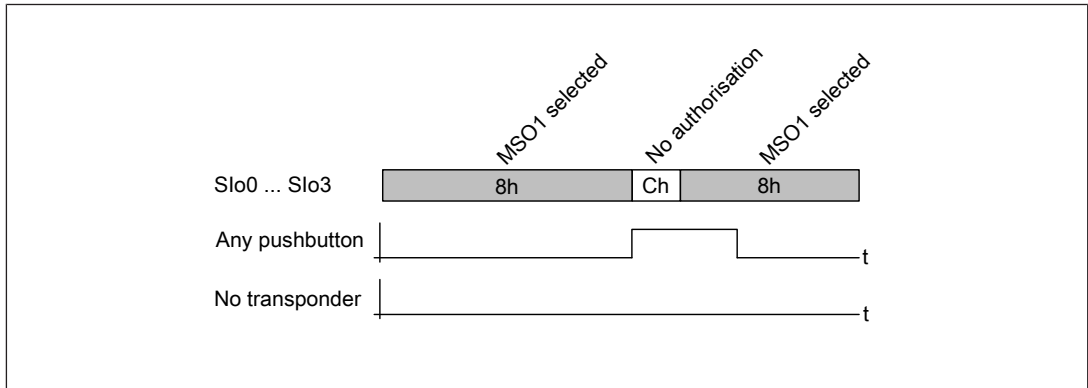

Fig.: Timing diagram for "Operating mode selection without transponder"

Operating mode selection with a transponder that does not have permission for the selected operating mode

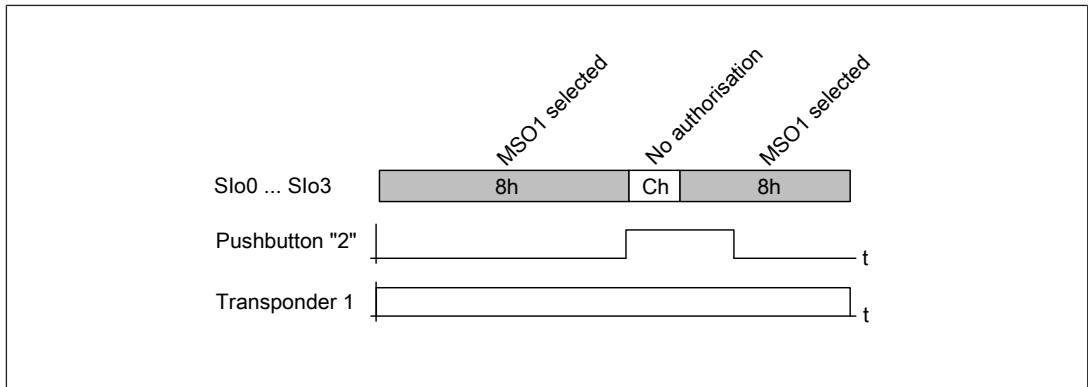

Fig.: Timing diagram for operating mode selection with insufficient permission for the operating mode to be selected

Operating mode selection with a transponder that does not have permission for the active operating mode

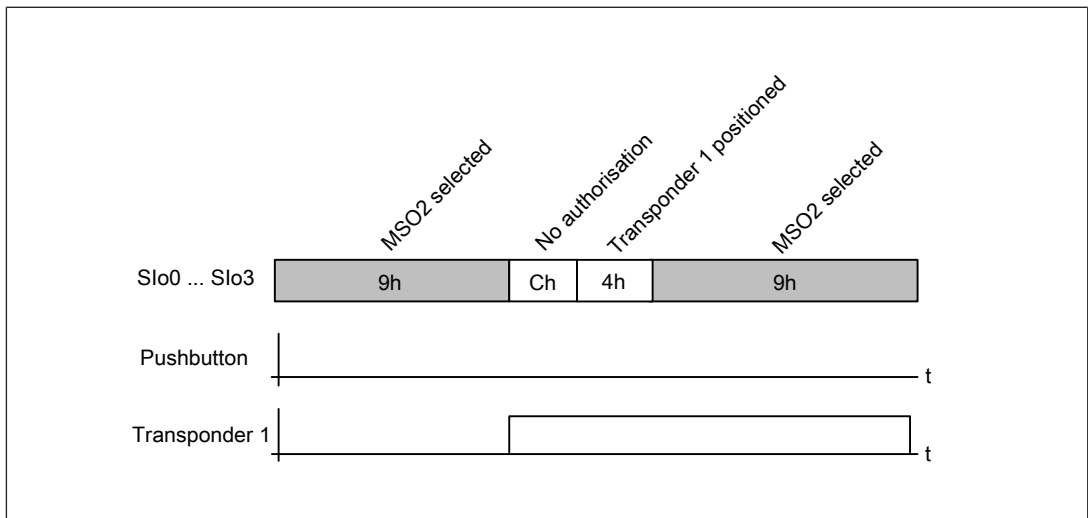

Fig.: Timing diagram for operating mode selection with insufficient permission for the active operating mode

Transponder not positioned in time before the operating mode is selected

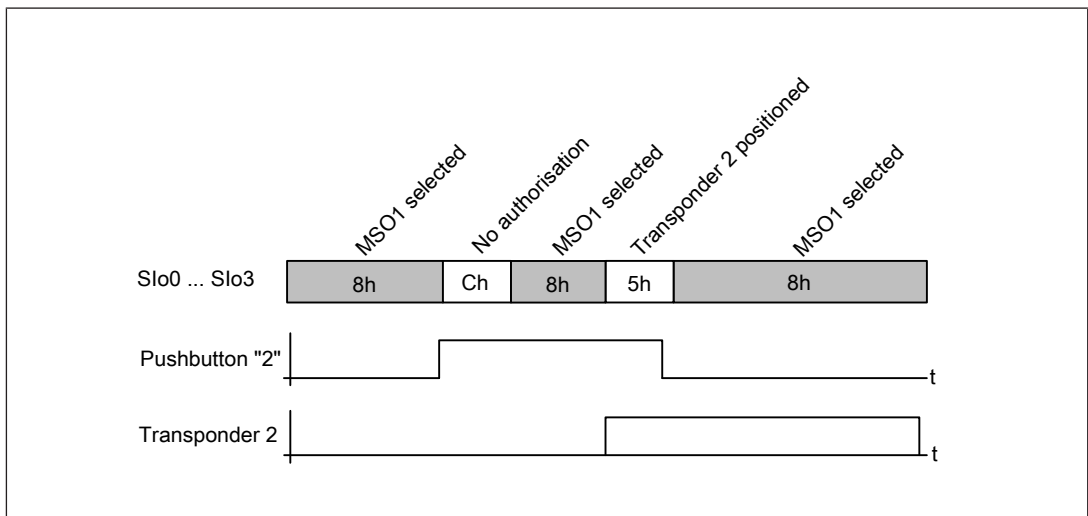



Fig.: Timing diagram for selecting the operating mode before the transponder is inserted

5.5.1.4

Application error: "Pushbutton operated incorrectly"

The following timing diagrams show how status information is registered at outputs Slo0 ... Slo3, based on the application errors "Pushbutton operated incorrectly".

Key:

| | |
|---|---|
|  | Message is displayed constantly |
|  | Message is displayed briefly (200 ms) |
| MSO | Mode of safe operation (operating mode) |

Multiple pushbuttons operated

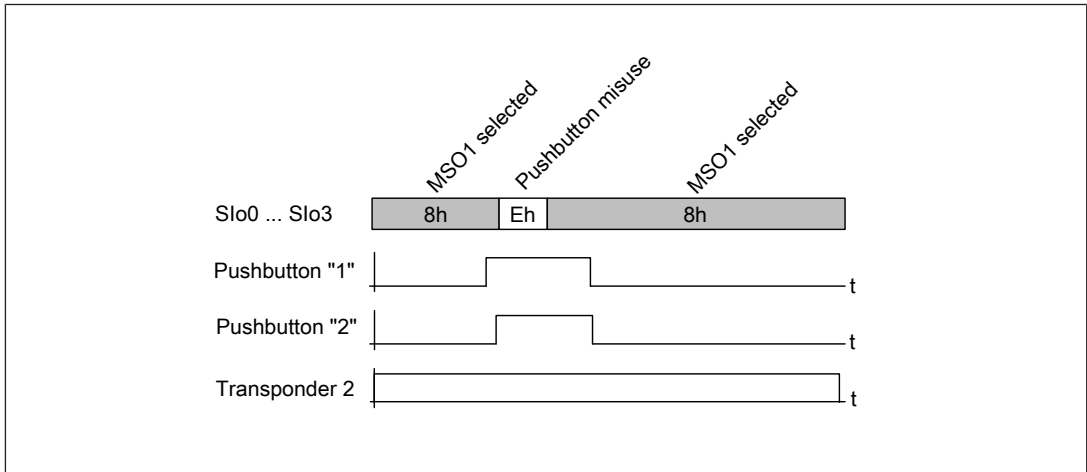

Fig.: Timing diagram for "Multiple pushbuttons operated"

Pushbutton operated for too long

- ▶ "Pushbutton operated for too long" with "Transponder 1" ... "Transponder 4" permissions
- or
- ▶ "Pushbutton operated for too long" with "Transponder Service" permission

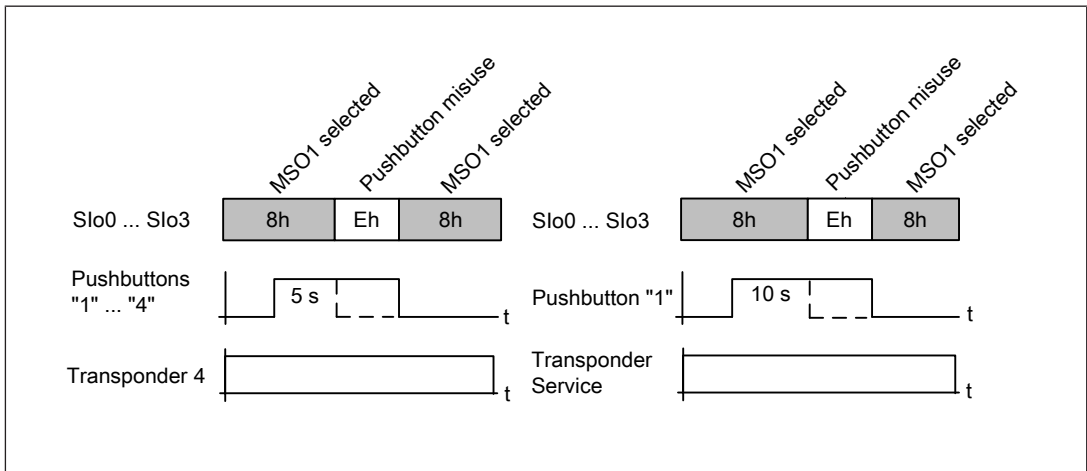

Fig.: Timing diagram for "Pushbutton operated for too long"

Button was released after the transponder was removed

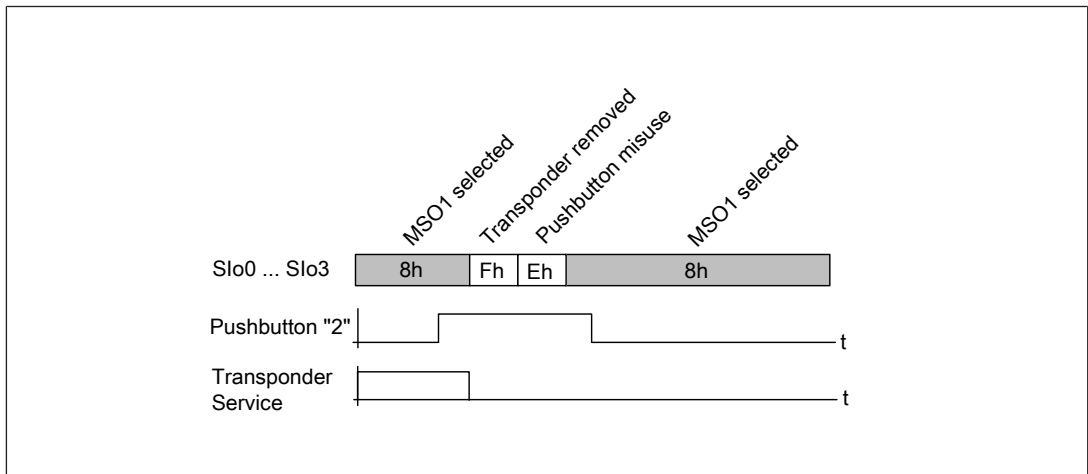

Fig.: Timing diagram for application error when the pushbutton is released

5.6 Key ID interface

The Key ID interface (see [Block diagram \[15\]](#)) is used to download the Key ID number to a controller.

5.6.1 Key ID number (serial number) of transponder

The Key ID number (serial number) is used to clearly identify the transponder and is unique. It is a 9-digit decimal number and can be read via the PITreader's web application.



NOTICE

Note:

The Key ID number is **not** printed on the transponder or on the transponder packaging.

If the transponder is lost, it is not possible to supply a replacement transponder with an identical Key ID number.

The Key ID number consists of two parts:

- ▶ Bit 27 = 24: Transponder (0 ... 15_D)
- ▶ Bit 23 = 00: Consecutive number (0 ... 9999999_D)

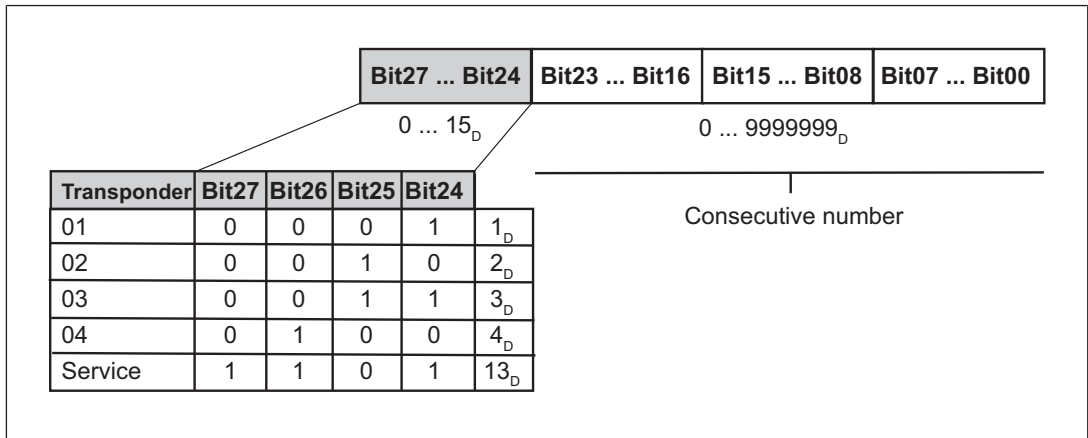
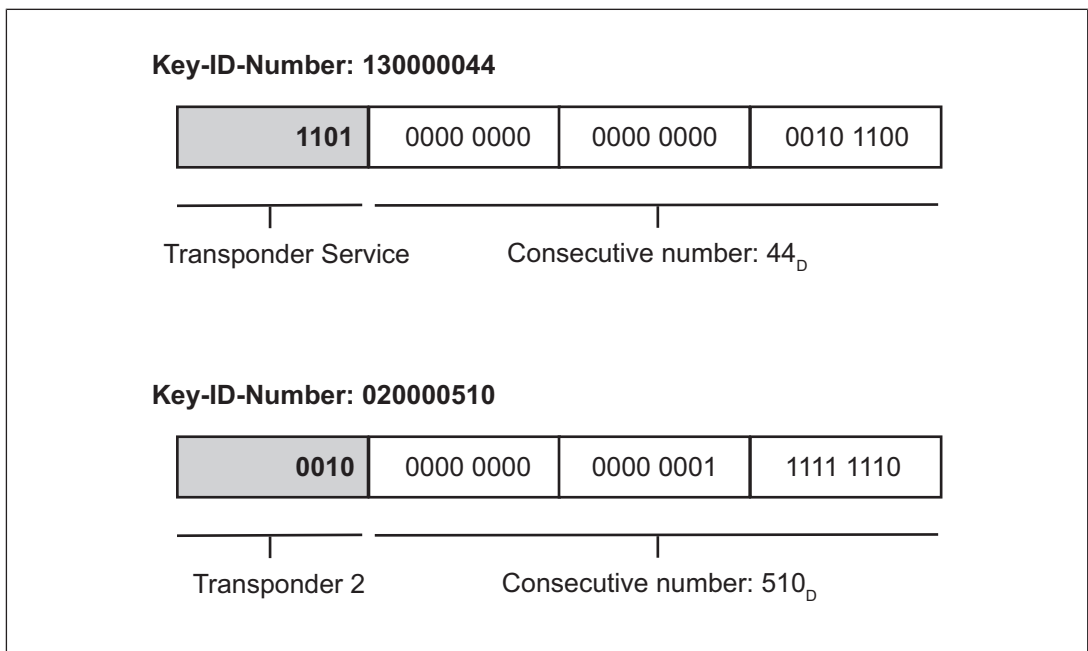

Fig.: Structure of the Key ID number

Examples:



5.6.2 Communication mode for downloading the Key ID number

The unique Key ID number for the relevant transponder is downloaded to the higher-level process controller using a defined protocol, depending on the coded communication mode. The communication mode is coded on the Key ID interface of the PIT m4SEU (jumpers available/not available).

The PIT m4SEU detects the coded communication mode at each power-on. As long as voltage is applied to the PIT m4SEU, the coded communication mode will be active; i.e. the change in communication mode does not come into effect until the supply voltage is switched off and then on again.

It is possible to choose between the following communication modes:

- ▶ Transmitter-controlled communication mode
- ▶ Handshake-controlled communication mode
- ▶ Advanced communication mode

5.6.2.1 Transmitter-controlled communication mode

With transmitter-controlled communication mode, the PIT m4SEU (= transmitter) starts the download of the Key ID number.

Features of this communication mode:

- ▶ Download of Key ID number starts once the transponder is positioned
- ▶ Constant bit rate (100 ms)
- ▶ Download on 2 data lines
- ▶ Constant download time (typ. 1.8 s)
- ▶ Monitored data download
- ▶ Input/outputs required on the controller: 4 inputs and 2 outputs
- ▶ Download is repeated by repositioning the transponder

No special coding is required on the Key ID interface in order to download the Key ID number of a transponder to the controller in transmitter-controlled communication mode. The terminals (see also [Terminal assignment](#)  48]) on the Key ID interface are used as follows:

| Key ID interface | Brief description of application | Assignment on controller | Coding |
|------------------|----------------------------------|--------------------------|--------------------|
| IDo0 | IDsync | Input | No coding required |
| IDo1 | IDclock | Input | |
| IDo2 | IDout0 | Input | |
| IDo3 | IDout1 | Input | |
| IDI0 | IDin0 | Output | |
| IDI1 | IDin1 | Output | |

5.6.2.2 Handshake-controlled communication mode

With handshake-controlled communication mode, the download of the Key ID number is started by the controller (Request).

Features of this communication mode:

- ▶ Download starts via a request from the controller, once the transponder is positioned
- ▶ Download is repeated by a renewed request from the controller
- ▶ Variable bit rate (min. 2 PLC cycles per bit)
- ▶ Download on 1 data line
- ▶ Min. download time: 28 Bit * (20 ms + 2 * PLC cycle)
- ▶ Identifier for ID end for plausibility check
- ▶ Input/outputs required on the controller: 3 inputs and 1 output

The Key ID interface must be coded with a jumper between IDo3 and IDi1 in order to download the Key ID number of a transponder to the controller in handshake-controlled communication mode. The terminals (see also [Terminal assignment](#)  48]) on the Key ID interface are used as follows:

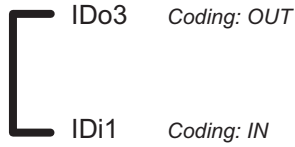
| Key ID interface | Brief description of application | Assignment on controller | Coding |
|------------------|----------------------------------|--------------------------|---|
| IDo0 | IDsync | Input | Coding via jumpers  |
| IDo1 | IDresponse | Input | |
| IDo2 | IDdata | Input | |
| IDo3 | <i>Coding: OUT</i> | n. c. | |
| IDi0 | IDrequest | Output | |
| IDi1 | <i>Coding: IN</i> | n. c. | |

In handshake-controlled communication mode, the PIT m4SEU can be operated in a functional variant. In this case the Key ID number of the transponder is not downloaded to the controller. The controller is only used to evaluate IDsync on the Key ID interface. In this case IDsync is used as a signal output, enabling the controller to recognise whether the transponder is valid/invalid. With this functional variant, only 1 input is required on the controller. The unused terminals on the Key ID interface (IDresponse, IDdata and IDrequest) may remain unwired ("open").

5.6.2.3 Advanced communication mode

In advanced communication mode, the download of the Key ID number behaves in the same way as the handshake-controlled mode. It differs from the handshake-controlled communication mode in so far that inputs are available for an operating mode lock and operating mode pre-selection (see [Operating mode lock \[41\]](#) and [Operating mode pre-selection \[43\]](#)).

Features of this communication mode:

- ▶ Download starts via a request from the controller, once the transponder is positioned
- ▶ Download is repeated by a renewed request from the controller
- ▶ Variable bit rate (min. 2 PLC cycles per bit)
- ▶ Download on 1 data line
- ▶ Min. download time: 28 Bit * (20 ms + 2 * PLC cycle)
- ▶ Identifier for ID end for plausibility check
- ▶ 2 inputs for operating mode lock and operating mode selection
- ▶ Input/outputs required on the controller: 3 inputs and 3 outputs

To enable the Key ID number of a transponder to be downloaded to the controller in advanced communication mode, the DIP switch must be set accordingly (see [Switching behaviour after permission is removed \[21\]](#)). The terminals (see also [Terminal assignment \[48\]](#)) on the Key ID interface are used as follows:

| | |
|----------------|---|
| IDclock | <p>Test pulse line</p> <p>The signal is generated by the PIT m4SEU and indicates the validity of the data bits at IDout0 and IDout1.</p> <ul style="list-style-type: none"> ▶ T = 100 ms ▶ Duty cycle = 50 % |
| IDout0, IDout1 | <p>Data lines for downloading the Key ID number</p> <p>The PIT m4SEU sends the Key ID number to the controller via these two data lines.</p> <p>Each download starts with the MSB.</p> <p>IDout0: Send Bit 27 ... Bit 14</p> <p>IDout2 Send Bit 13 ... Bit 00</p> |
| IDin0, IDin1 | <p>Data line for reading back the Key ID number</p> <p>The controller sends the previously received Key ID number back to the PIT m4SEU via these two data lines.</p> <p>IDin0: Receive Bit 27 ... Bit 14</p> <p>IDin1 Receive Bit 13 ... Bit 00</p> |

Download procedure

- [a] The PIT m4SEU sets the signal at IDsync (control line) to "1" for 100 ms, thereby signalling to the controller that download has started.
- [b] A rising edge at IDclock (test pulse line) indicates that the data at data lines IDout0 and IDout1 is present and valid and can be read by the controller.
- [c] By the falling edge at IDclock (test pulse line), the controller must send the previously read bit back to the PIT m4SEU via the data lines IDi0 and IDi1.
- [d] Before the rising edge at IDclock (test pulse line), the PIT m4SEU reads the bits sent back to IDi0 and IDi1 by the controller and checks them for equivalence.
- [e] At least 60 ms after the falling edge at IDclock (test pulse line), the last bit sent back by the controller must be present at data lines IDin0 and IDin1.
- [f] A maximum of 100 ms after the falling edge at IDclock (test pulse line), the last bit sent back by the controller must be present at data lines IDin0 and IDin1; in other words, by this point at the latest, the data download must be completed and the data lines must have a "0" signal.



INFORMATION

If the controller does not feed back the previously read bits correctly, the download is aborted and restarted. The "IDsync" signal is set once again. The download is repeated until the Key ID number is downloaded in full.

It typically takes 1.8 s to download the Key ID number.

Flowchart for evaluating the Key ID interface

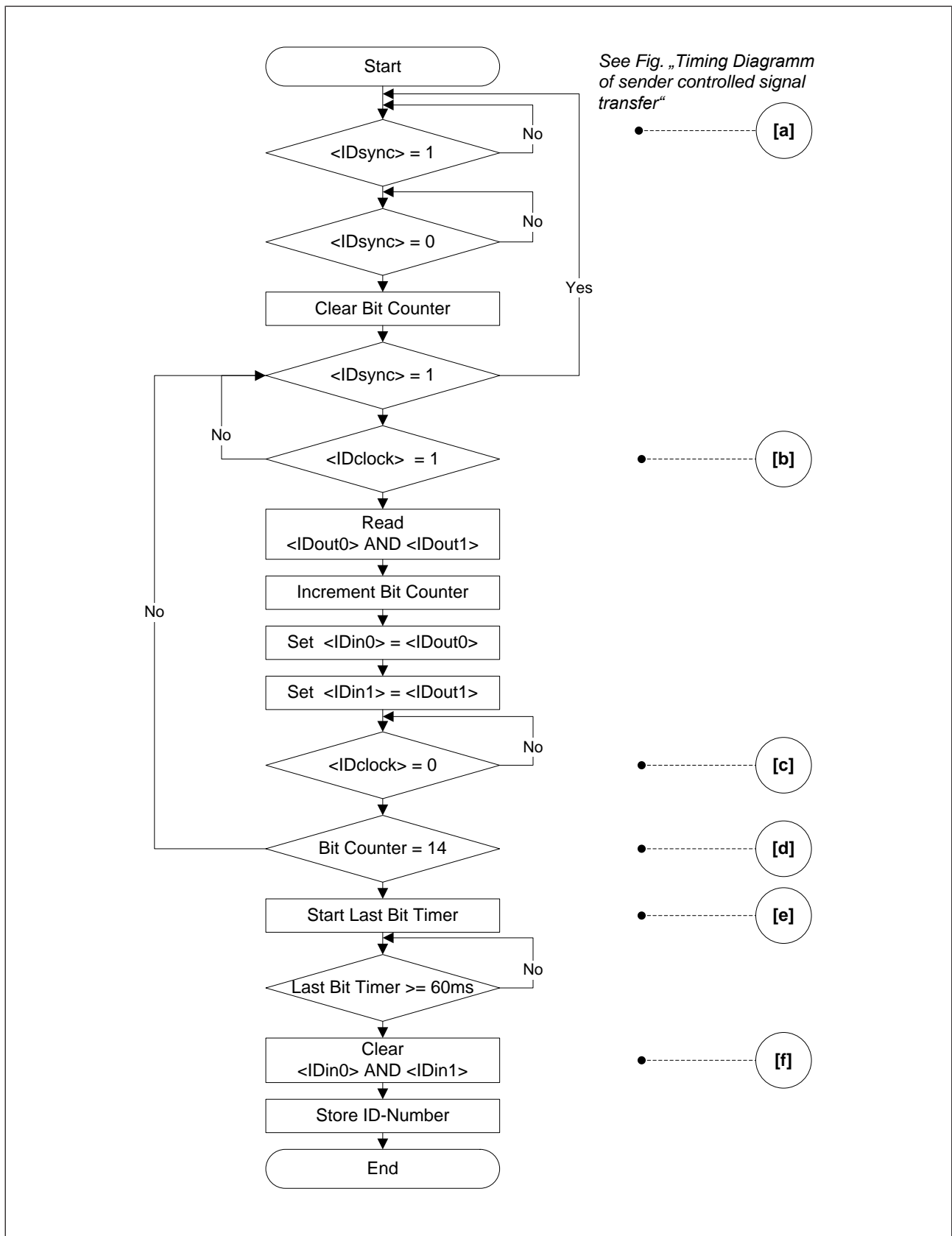

Fig.: Evaluation of the Key ID number via a controller (principle)

5.6.3.2 Evaluation of the Key ID number with handshake-controlled communication

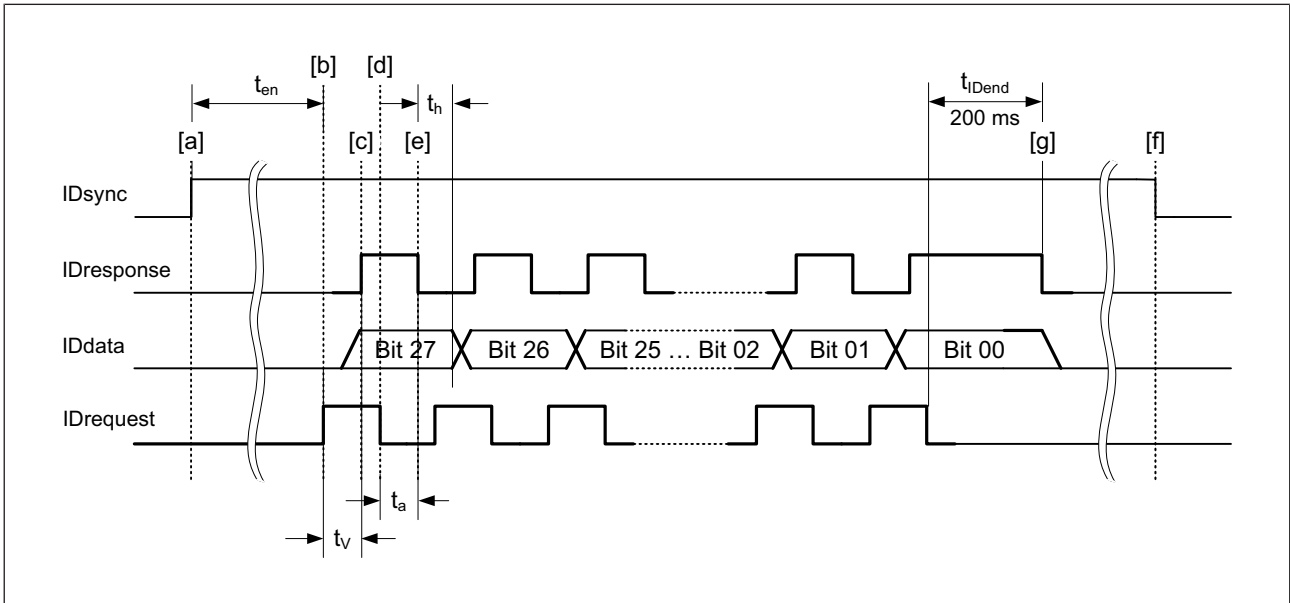

Fig.: Timing diagram for handshake-controlled signal download

Legend

To assign the terminal designations to the short descriptions, please note the table in [Handshake-controlled communication mode](#) [32].

- IDsync Control line
The signal is generated by the PIT m4SEU.
"0" signal No transponder is positioned or the transponder that is positioned is invalid. The controller cannot request the Key ID number.
"1" signal A valid transponder is positioned and the controller can request the Key ID number.
- IDresponse Handshake line (Response)
The signal is generated by the PIT m4SEU and indicates whether a data bit at IDdata is valid/invalid.
"0" signal The data bit at IDdata is invalid and may not be evaluated.
"1" signal The data bit at IDdata is valid and may be evaluated.
- IDdata Data line for downloading the Key ID number
The Key ID number (28 Bit) is generated by the PIT m4SEU. The download begins with the MSB (Bit27 ... Bit00).
- IDrequest Handshake line (Request)
The signal is generated by the controller.
"0" signal No bit is requested at IDdata
"1" signal A new bit is requested at IDdata.

- t_{en} IDsync Enable Time (min. 0 ms)
- t_v Data Output Valid Time (max. 10 ms)
- t_h Data Output Hold Time (min. 0 ms)
- t_a Data Output Access Time (max. 10 ms)
- t_{IDend} End of Key ID Number Transfer (200 ms)
After the last falling edge at IDrequest, the PIT m4SEU still has a "1" signal at output IDresponse for 200 ms. In this way, the end of the Key ID number and therefore the end of the download (End of Key ID Number Transfer) is displayed. This can be used for the plausibility check.

Download procedure

- [a] "1" signal at IDsync (control line):
A transponder that is recognised as valid is positioned in the read area of the PITreader.
- [b] "1" signal at IDrequest (handshake line):
The controller requests a data bit at data line IDdata.
- [c] "1" signal at IDresponse (handshake line):
The PIT m4SEU confirms the validity of the data bit at data line IDdata.
- [d] "0" signal at IDrequest (handshake line):
The controller confirms that it has read the requested data bit without error.
- [e] "0" signal at IDresponse (handshake line):
The PIT m4SEU is ready to issue a new data bit at data line IDdata.
- [f] "0" signal at IDsync (control line):
The transponder was removed.
- [g] The controller must request all the data bits of a Key ID number (Bit27 ... Bit00).
Only then is it possible to start downloading a new Key ID number. The end of the download is indicated by the signal extension (t_{IDend}) at IDresponse.

Status diagram for handshake-controlled signal download

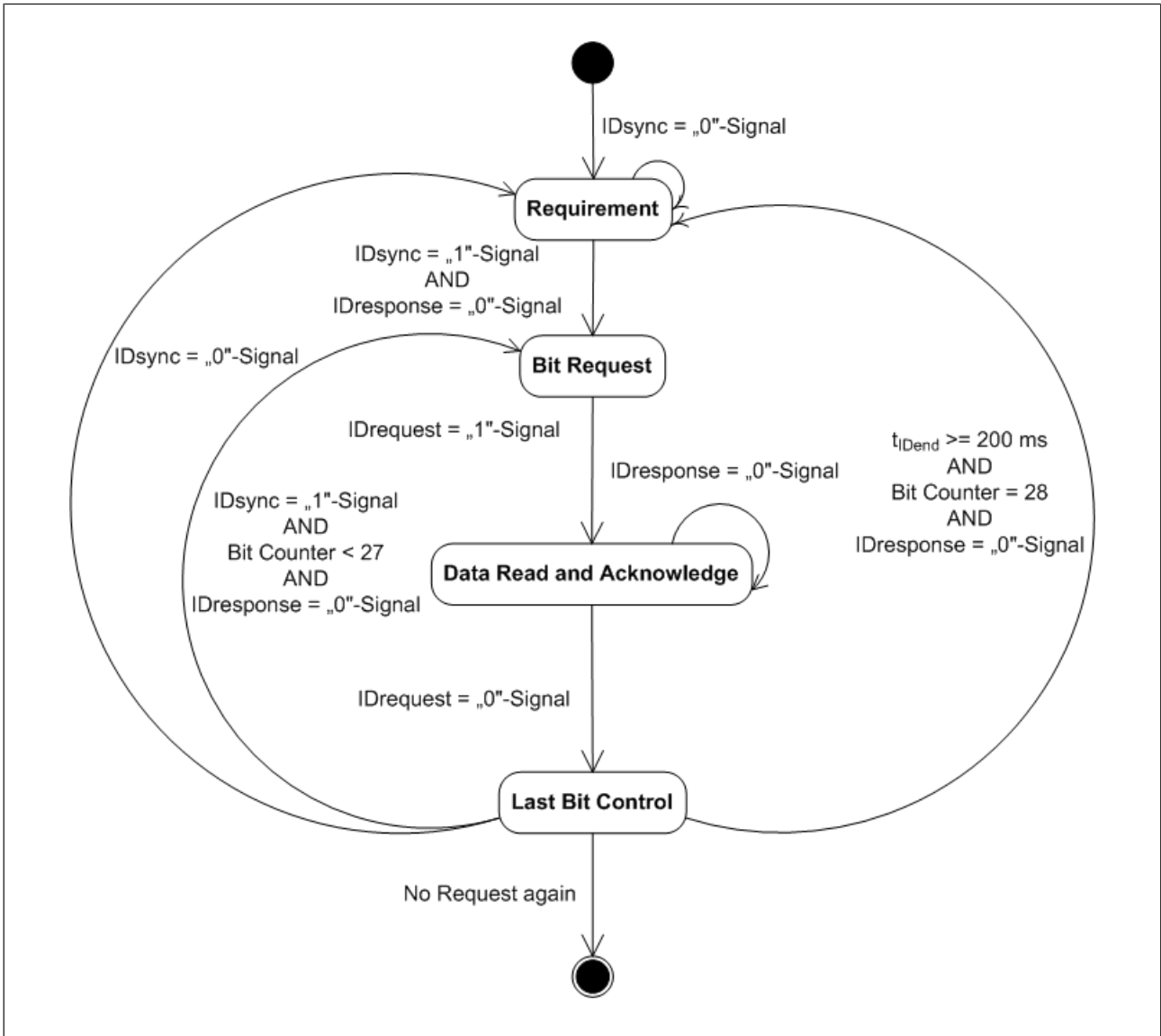

Fig.: Status diagram for handshake-controlled signal download

Flowchart for evaluating the Key ID interface

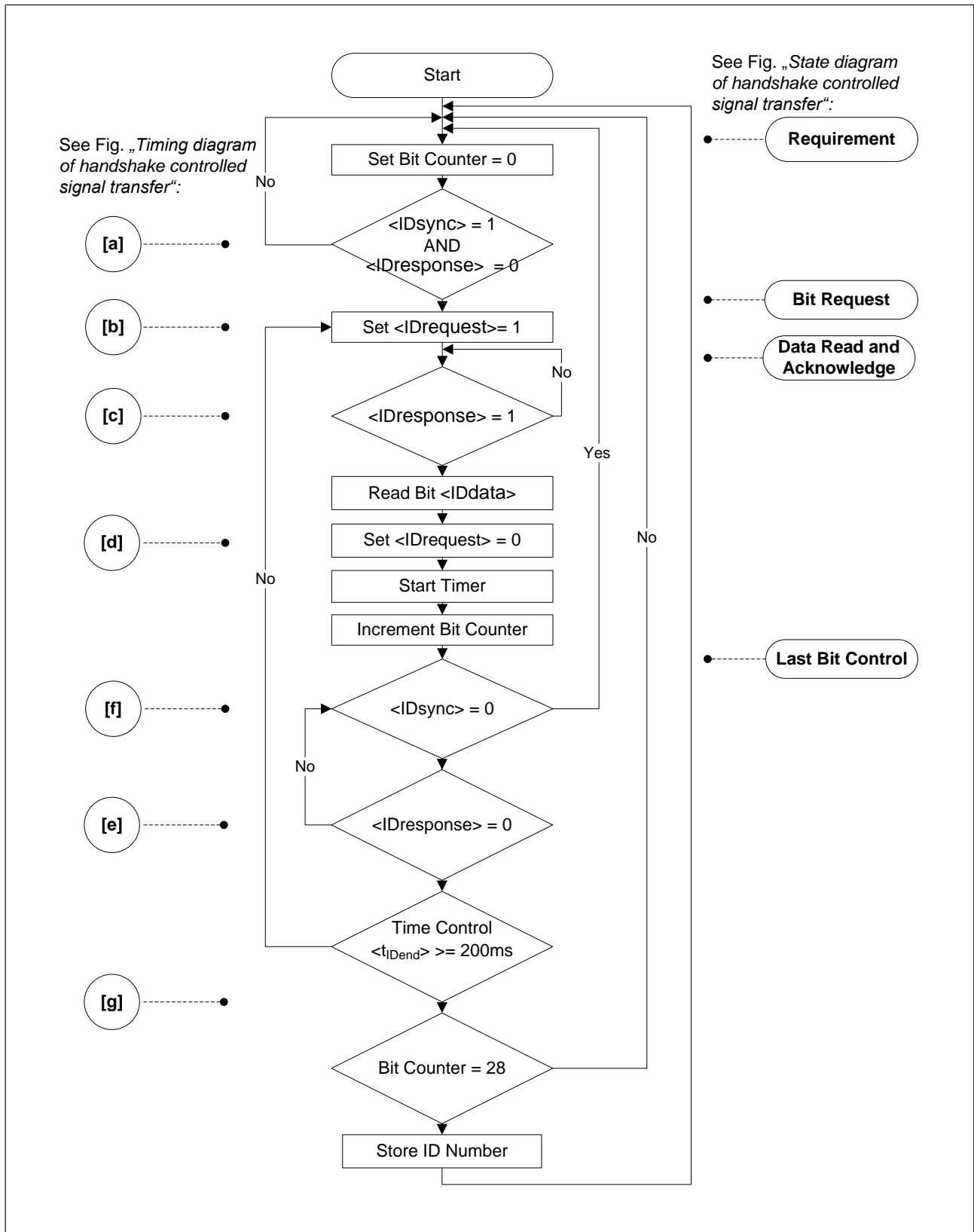



Fig.: Evaluation of the Key ID number via a controller (principle)

5.6.3.3 Evaluation of the Key ID number with advanced communication

Evaluation of the Key ID number in advanced communication mode is identical to the handshake-controlled communication mode. Please refer to the timing diagram and the flow-chart from the previous section [Handshake-controlled communication mode](#)  32].

In advanced communication mode, two control signals are also available:

- ▶ acknowledge → to adopt the preselected operating mode
- ▶ lock → to lock the change of operating mode

Both signals are sent from the controller to the PIT m4SEU. These are standard inputs that do **not** affect the safety function of the PIT m4SEU.

5.7 PITreader interface

The PITreader interface contains an internal interface for communication with the authentication system PITreader and a voltage output for its supply voltage. The following information is downloaded via a defined protocol:

- ▶ Permission is received
- ▶ Status information is sent, in accordance with the [Interface for status information](#)  22]

Only transponders with permission 1-5 are registered on the PIT m4SEU. With any other permissions, the PIT m4SEU does not receive any information via the positioned transponder.

After the transponder is removed, permission to select operating modes is locked after the reaction time t (see Technical details).

The voltage output may only be used for the supply voltage for the authentication system PITreader.

5.8 Operating mode lock and operating mode preselection

5.8.1 Operating mode lock

The function of the operating mode lock is to enable and disable the request for a change of operating mode via a digital input.

A change of operating mode can be triggered by:

- ▶ Operating the pushbutton
- ▶ Removing the transponder with operating mode fallback and service fallback

When a change of operating mode is requested during the operating mode lock,

- ▶ The corresponding display element flashes briefly,
- ▶ The interface for status information signals "No permission" and
- ▶ The operating mode outputs do not switch.

You can deactivate the function, although it is configured. To do this, connect a "1" signal to input IDi0.



NOTICE

The operating mode lock is **not** a safety-related function. Switching of the operating mode has to be validated in accordance with the requirements.

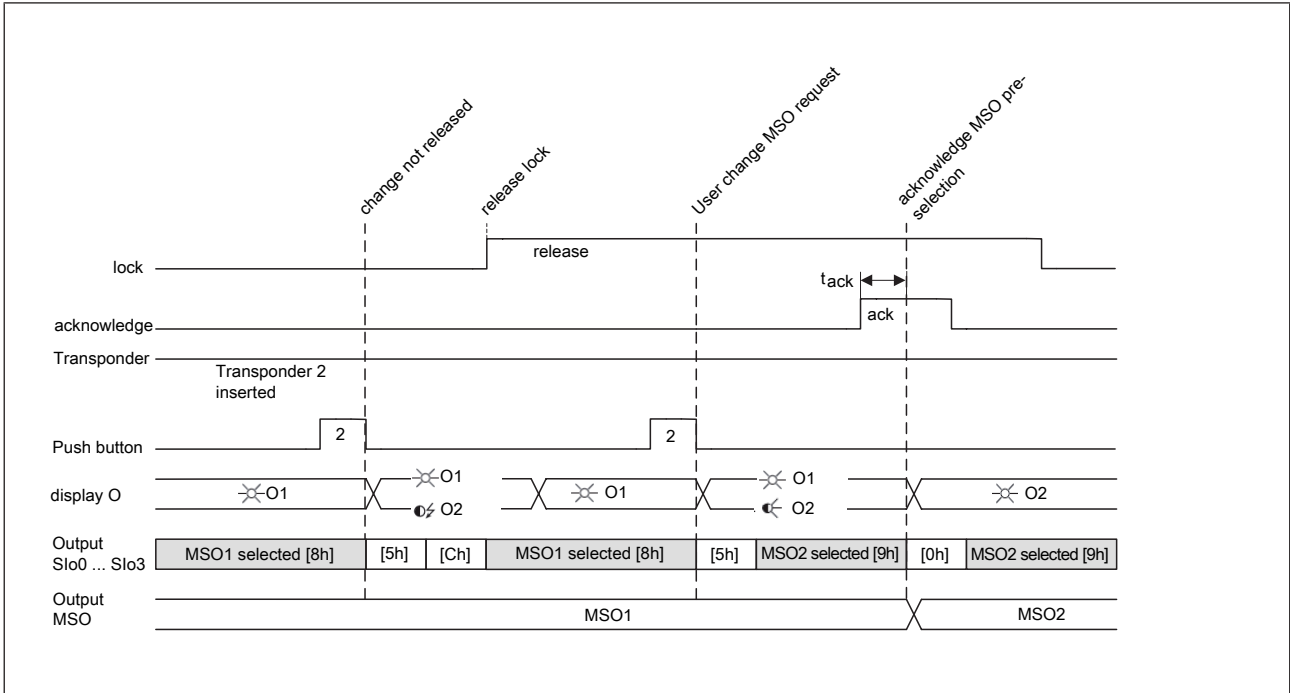

Fig.: Changing the operating mode after operating the pushbutton, with DIP switch settings [D5] to [D8]

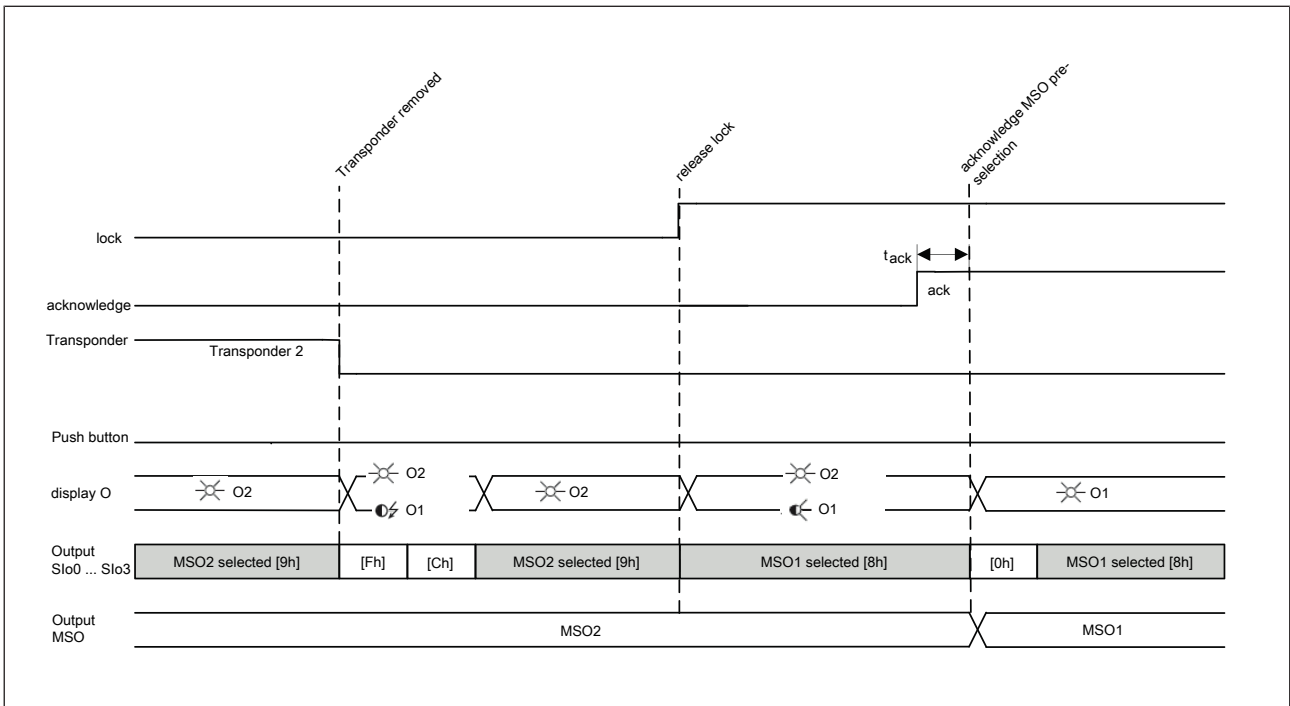

Fig.: Changing the operating mode after removing the transponder, with DIP switch settings [D7]

Legend

To assign the terminal designations to the short descriptions, please refer to the table in [Advanced communication mode \[33\]](#).

| | |
|------------------|---|
| MSO | Mode of safe operation |
| t_{ack} | Acknowledge time min. 120 ms. |
| lock | Selection lock, control signal is generated by the controller and must be present for at least 20 ms for the signal state to be adopted |
| "0" signal | Locking the change of operating mode and/or ending an operating mode preselection |
| "1" signal | Enabling the change of operating mode and/or resuming an operating mode preselection |
| acknowledge | Acknowledgement, control signal is generated by the controller. "0" signal must be present for at least 20 ms for the signal state to be adopted. |
| "0" signal | Preventing the switching of operating mode outputs |
| "1" signal | Enabling the switching of operating mode outputs |
| display O | Illumination of display element |
| Output | Interface for control information |
| Slo0 ... Slo3 | |
| Output MSO | Operating mode outputs |

5.8.2 Operating mode preselection

The function of operating mode preselection is to use a digital input to prevent or confirm the switching of the operating mode during an operating mode change, depending on the process requirement. Only the last operating mode preselection is confirmed by the controller.

You can deactivate the function, although it is configured. To do this, connect a "1" signal to input IDi1.

Display during operating mode preselection

- ▶ The display element indicates the selected operating mode by being lit continuously. The flashing of a display element indicates a preselected operating mode (see [Status information via the signal outputs \[59\]](#)).
- ▶ The interface for status information displays the preselected operating mode (see [Interface for status information \[22\]](#)).
- ▶ The operating mode outputs display the selected operating mode (see [Operating mode interface \[21\]](#)).

When operating mode storage is configured, the last confirmed operating mode is adopted when the device is restarted. The operating mode preselection is not stored.

Display after operating mode preselection, when this has been confirmed

- ▶ Operating mode outputs switch to the preselected operating mode.
- ▶ The interface for status information still displays the same operating mode and confirms the transfer of the preselected operating mode to the selected operating mode with the status information "Operating mode preselection switched" (see [Interface for status information \[22\]](#)).

- ▶ The display element for the newly selected operating mode is lit constantly and the display element for the last confirmed operating mode goes out.

Undoing an operating mode preselection

By the user:

- ▶ Operate the pushbutton for the selected operating mode (corresponding display element is lit continuously)
- ▶ Position the transponder in the event of operating mode fallback and service fallback; permission must be equal to or higher than the previously removed permission.

By the controller:

- ▶ "0" signal at the lock input

Please note that removing the transponder from the read area of the PITreader does not reset the operating mode preselection.



NOTICE

The operating mode preselection is **not** a safety-related function. Switching of the operating mode has to be validated in accordance with the requirements.

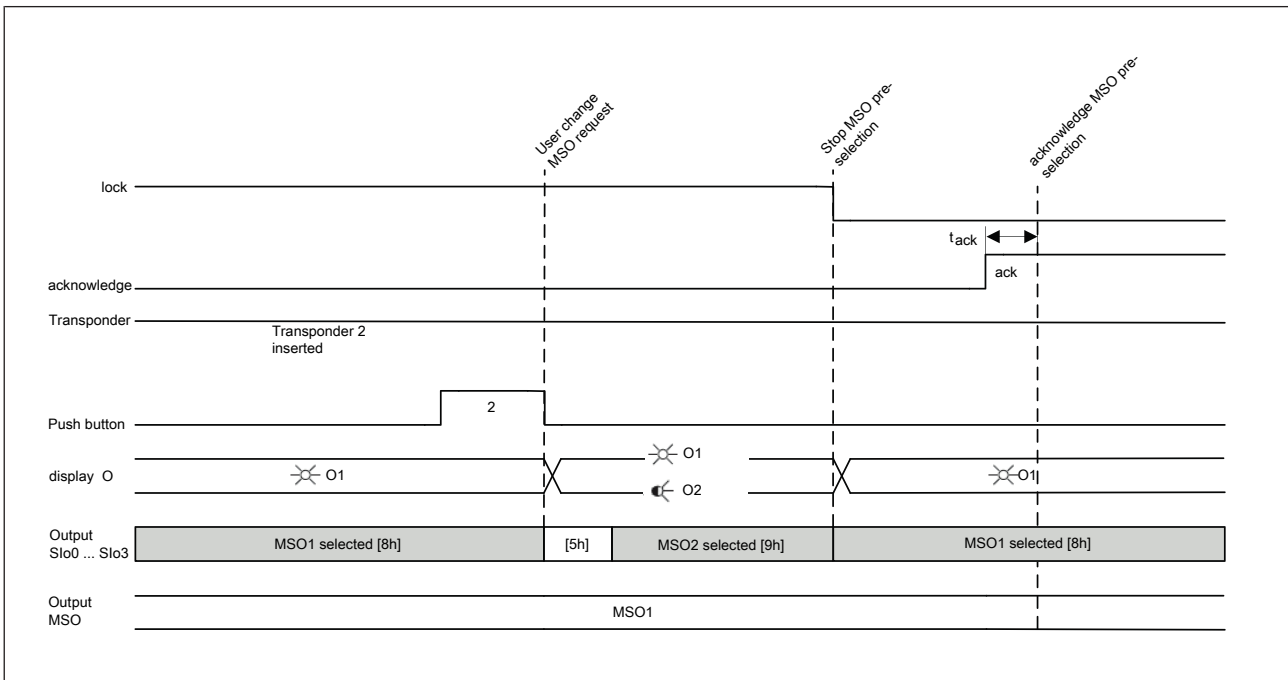

Fig.: Exiting the operating mode preselection after the pushbutton has been operated, with DIP switch setting [D5] to [D8]

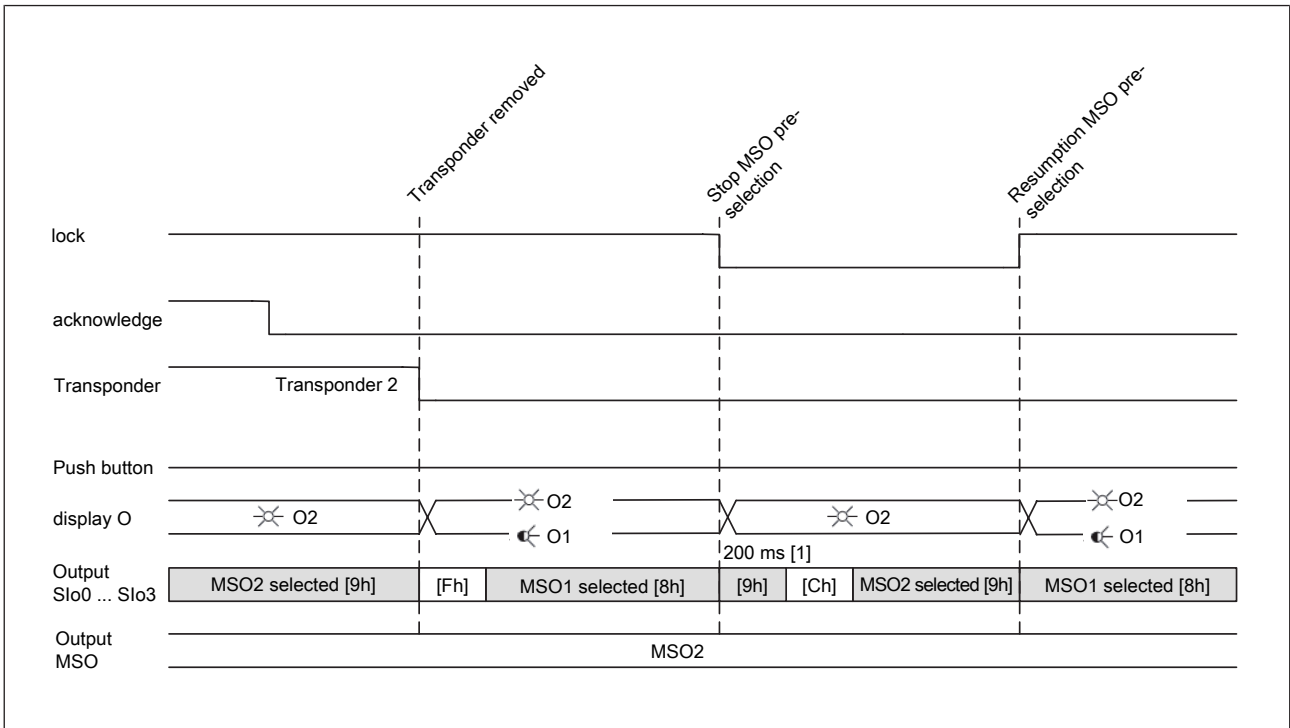

Fig.: Exiting the operating mode preselection after removing the transponder, with DIP switch setting [D7]

Legend

To assign the terminal designations to the short descriptions, please refer to the table in [Advanced communication mode \[33\]](#).

| | |
|----------------------|---|
| MSO | Mode of safe operation |
| t_{ack} | Acknowledge time min. 120 ms. |
| lock | Selection lock, control signal is generated by the controller and must be present for at least 20 ms for the signal state to be adopted |
| "0" signal | Locking the change of operating mode and/or ending an operating mode preselection |
| "1" signal | Enabling the change of operating mode and/or resuming an operating mode preselection |
| acknowledge | Acknowledgement, control signal is generated by the controller. "0" signal must be present for at least 20 ms for the signal state to be adopted. |
| "0" signal | Preventing the switching of operating mode outputs |
| "1" signal | Enabling the switching of operating mode outputs |
| display O | Illumination of display element |
| Output Slo0 ... Slo3 | Interface for control information |
| Output MSO | Operating mode outputs |

6 Installation

6.1 General installation guidelines

- ▶ Install the device in a control cabinet or control console.
- ▶ Use the notch on the rear of the device to attach it to a mounting rail (35 mm).
- ▶ When installed vertically: Secure the device by using a fixing element (e.g. retaining bracket or end angle).

6.2 Dimensions in mm

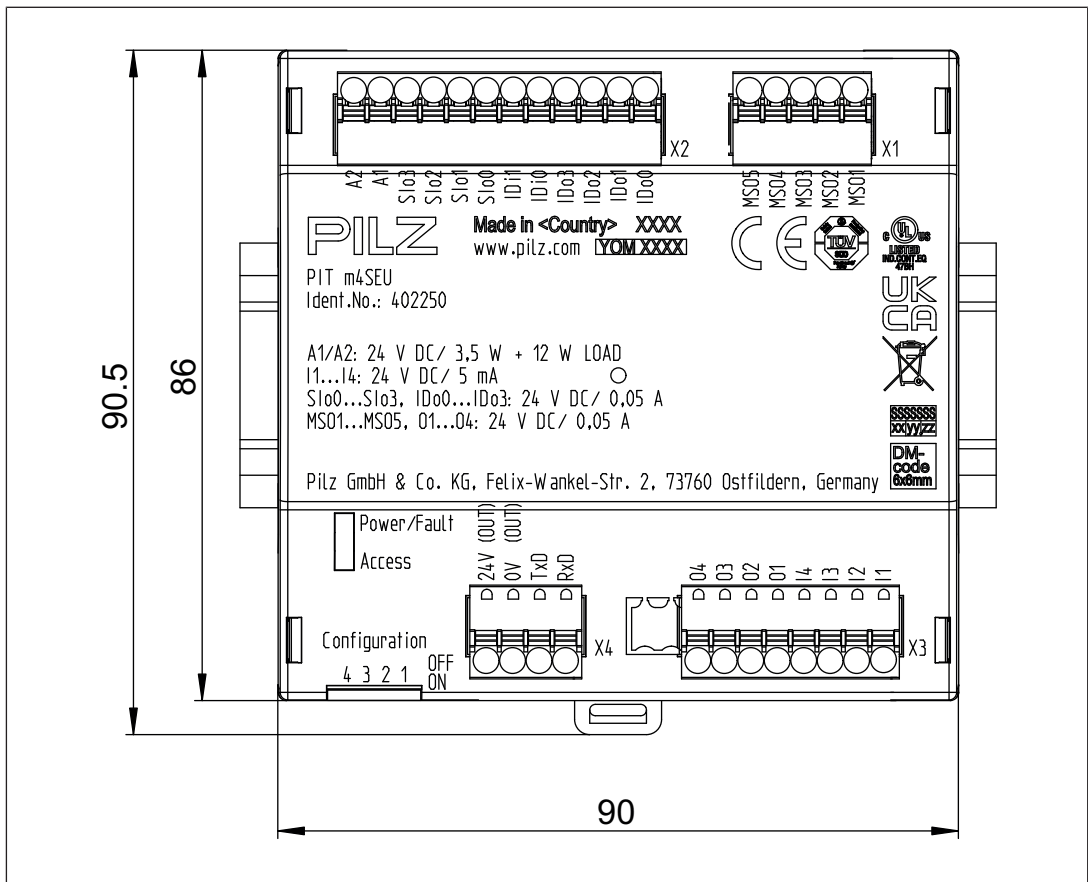

Fig.: Front view (installed on top-hat rail)

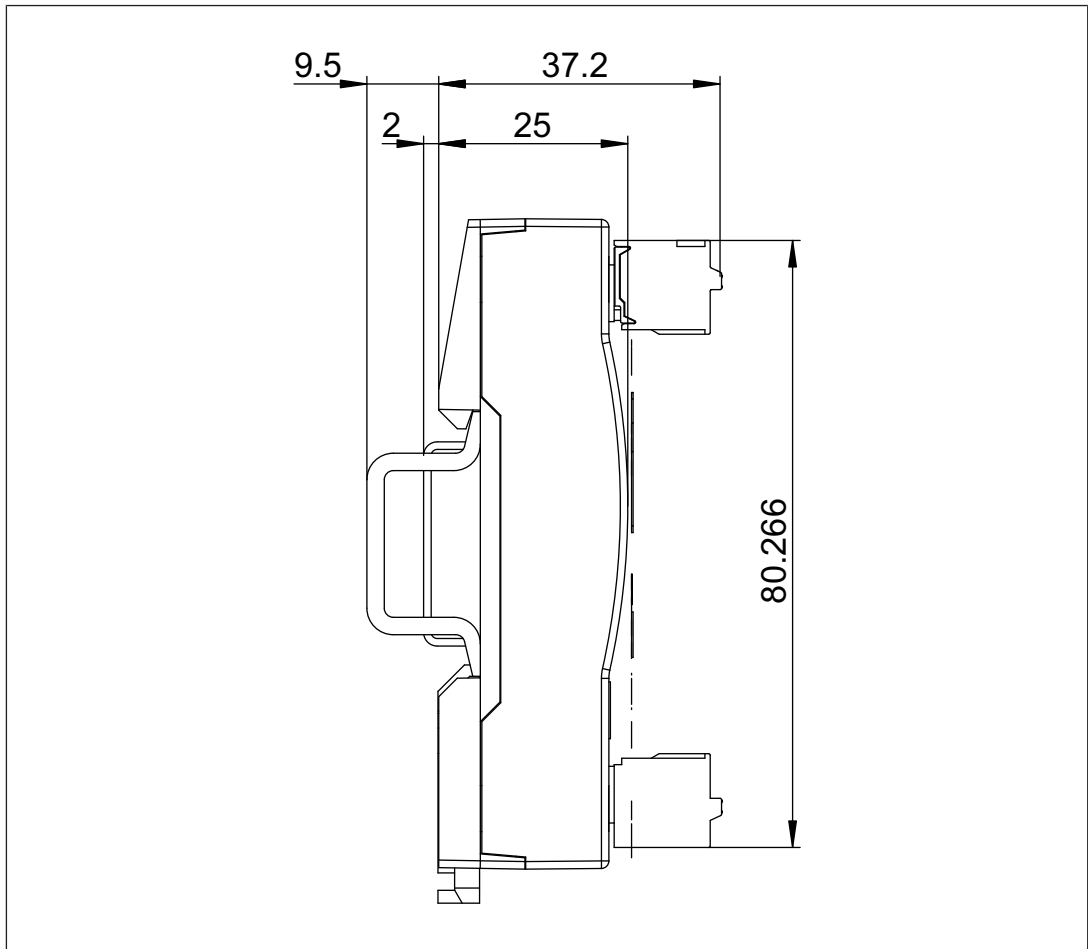

Fig.: View from below

7 Wiring

7.1 Terminal configuration



INFORMATION

The connection terminals are not supplied with the unit.

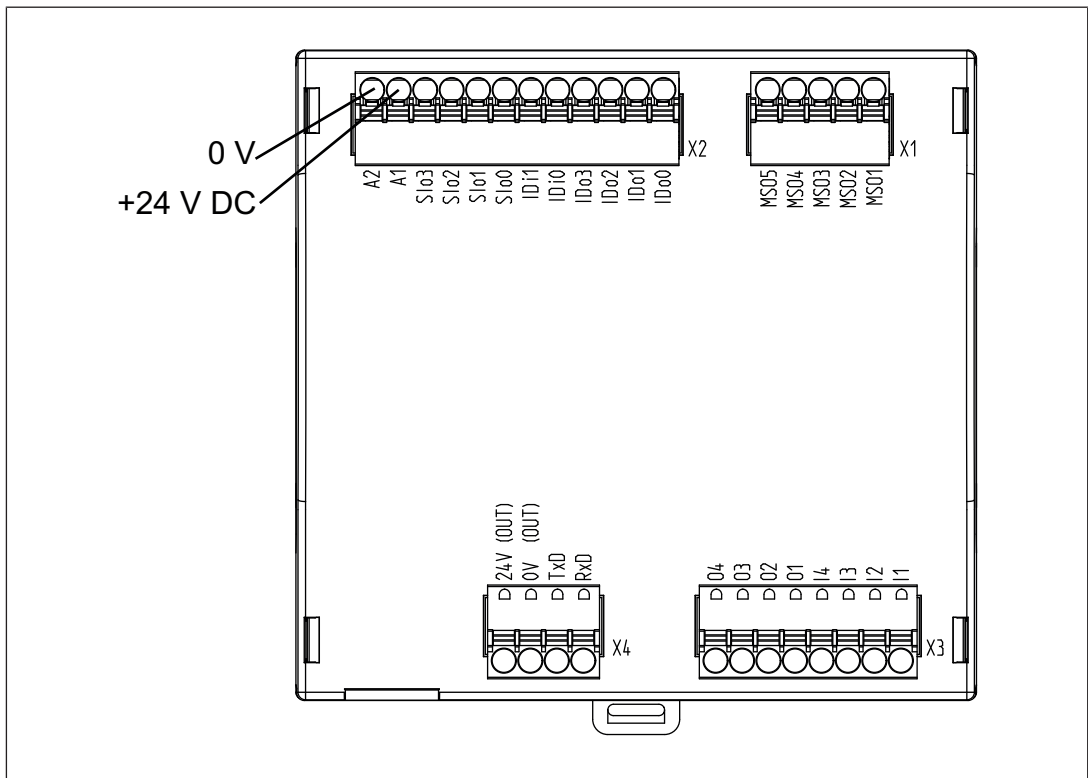

Fig.: Terminal configuration

Legend

| | | |
|----|---|--|
| X1 | MS01 ... MS05 | Operating mode interface: monitored semiconductor outputs for operating modes 1 ... 5 |
| X2 | A1, A2 S1o0 ... S1o3 IDi0 ... IDi1 IDo0 ... IDo3 | Terminals for connecting the supply voltage Interface for status information: Evaluation of status information Key ID interface: Inputs for receiving the input signals from the controller The function of the terminals depends on the communication mode that has been configured Key ID interface: Semiconductor outputs for sending the output signals to the controller The function of the terminals depends on the communication mode that has been configured. |

| | | |
|----|-------------------|---|
| X3 | I1 ... I4 | Inputs for connecting external pushbuttons to select the operating mode |
| | O1 ... O4 | Outputs for connecting external display elements |
| X4 | 24V, 0V, TxD, RxD | PITreader interface |

7.2 Connecting the unit

Follow the instructions below:

1. Connect the supply voltage
 - ⇒ Connect the supply voltage to (A1, A2).



NOTICE

The power supply must meet the regulations for extra low voltages with protective separation (SELV, PELV).

The cables for the device's supply voltage (A1, A2) must be fitted with a 4 A fuse, characteristic B/C.





NOTICE

Guideline for UL certification:

The device shall be supplied from an isolating transformer having a secondary Listed fuse rated either:

- max 5 amps for voltages 0~20 V (0~28.3 Vp), or
- 100/Vp for voltages of 20~30 V (28.3~42.4 Vp).

2. Connect PITreader
 - ⇒ Connect the PITreader via the PITreader interface.
The PITreader is supplied from the 24V/0V voltage outputs on the PIT m4SEU in order to avoid potential differences. The connections of RxD and TxD on the PIT m4SEU should be crossed. The cable length between the two devices may be max. 20 m.
3. Connect pushbutton
 - ⇒ At the inputs I1 ... I4, connect external pushbuttons with N/O contact to select the operating mode (for details of the allocation of the pushbutton inputs Ix to the outputs MSOx see [Operating mode interface](#) [📖 21]). You only need to assign the pushbutton inputs for the operating modes you require; the rest can remain unassigned.
4. Connect display elements
 - ⇒ At the signal outputs O1 ... O4, connect external display elements to display the selected operating mode (for details of the allocation of the signal outputs Ox to the pushbutton inputs Ix see [Inputs and signal outputs for operating mode selection or operating mode interface](#) [📖 17]). You only need to assign the signal outputs for the operating modes you require; the rest can remain unassigned.

5. Connecting the operating mode interface's semiconductor outputs
 - ⇒ Connect the operating mode interface's semiconductor outputs to a controller that supports "1oon" evaluation.
You must read the information concerning intended use (see [Intended use](#) [ 11]).
6. Connecting the terminals for the interface for status information
 - ⇒ Connect the terminals (SIo0 ... SIo3) to a controller that supports evaluation of the status information.
7. Use jumpers to code the communication mode for downloading the Key ID number (alternative configuration via DIP switch settings, see [Configuration of functions](#) [ 18])
 - Coding via jumpers is not required for the transmitter-controlled communication mode.
 - To download the Key ID number in handshake-controlled communication mode, code the Key ID interface via a jumper between terminals IDo3 and IDi1.
 - Coding via jumpers is not required for advanced communication mode.
8. Connect the terminals of the Key ID interface
 - ⇒ Depending on the selected communication mode, connect the terminals of the Key ID interface to a controller that supports the download of the Key ID number.

or

 - ⇒ Connect IDsync to a controller, if all you wish to do in handshake communication mode is evaluate whether a transponder is valid/invalid. In this case you will only use IDsync as a signal output. The unused terminals on the Key ID interface (IDresponse, IDdata and IDrequest) may remain unwired ("open").

7.3 Connection to a controller

The examples below meet the following conditions:

- ▶ A PNOZmulti 2 base unit is used as a safety controller.
- ▶ An "operating mode selector switch" function element is configured in the PNOZmulti Configurator for safe "1oon" evaluation.
- ▶ The Key ID interface and the interface for status information are evaluated via a higher-level process controller.
- ▶ The cables for the device's supply voltage (A1, A2) contain a 4 A fuse, characteristic B/C.



NOTICE

After wiring, the PIT m4SEU must be subjected to a full function test in the plant.



INFORMATION

The inputs on the FS-PLC operating mode evaluation module cannot be configured with test pulse monitoring.

Connection for transmitter-controlled communication mode

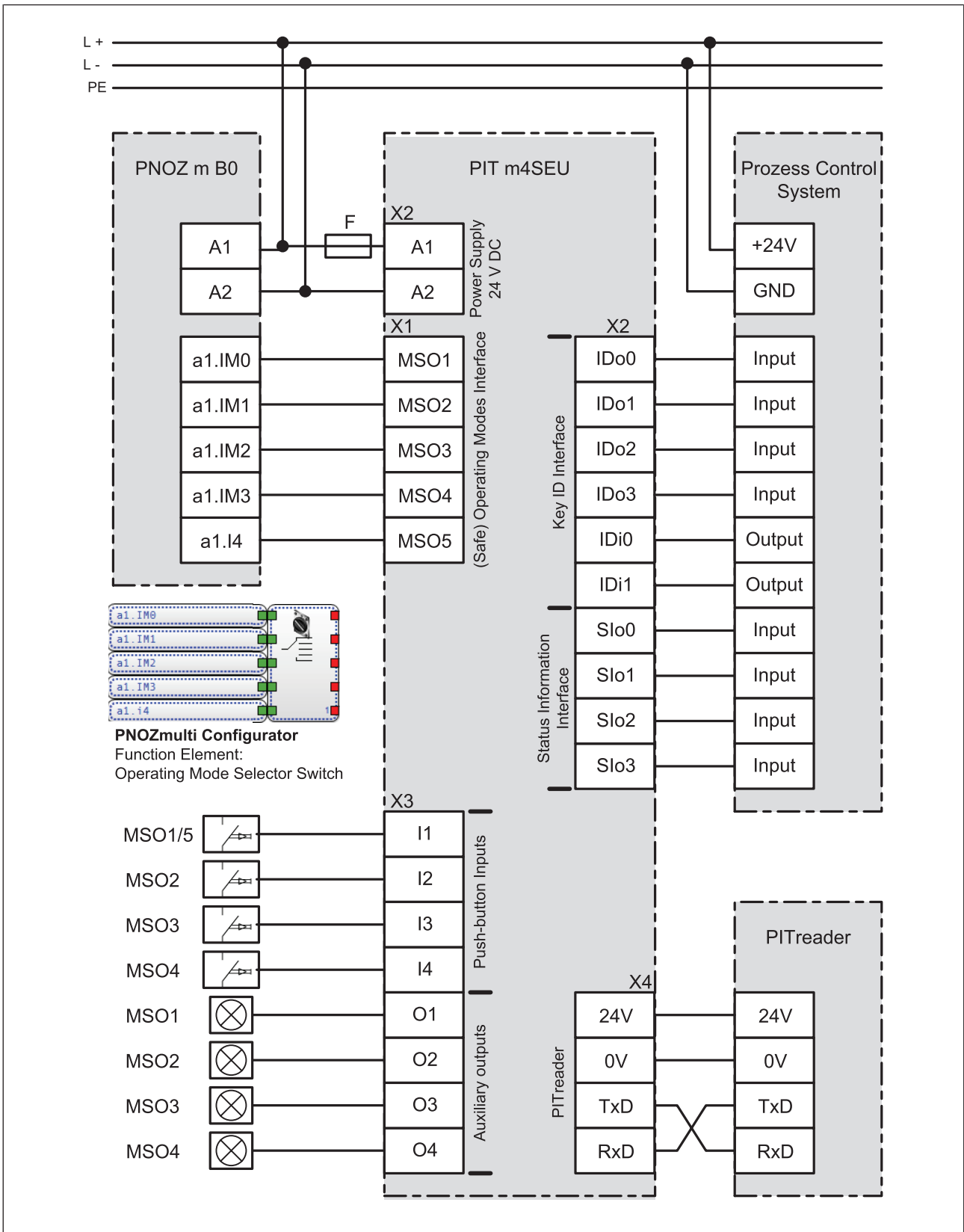

Fig.: Connection for transmitter-controlled communication mode (example)

Connection for handshake-controlled communication mode

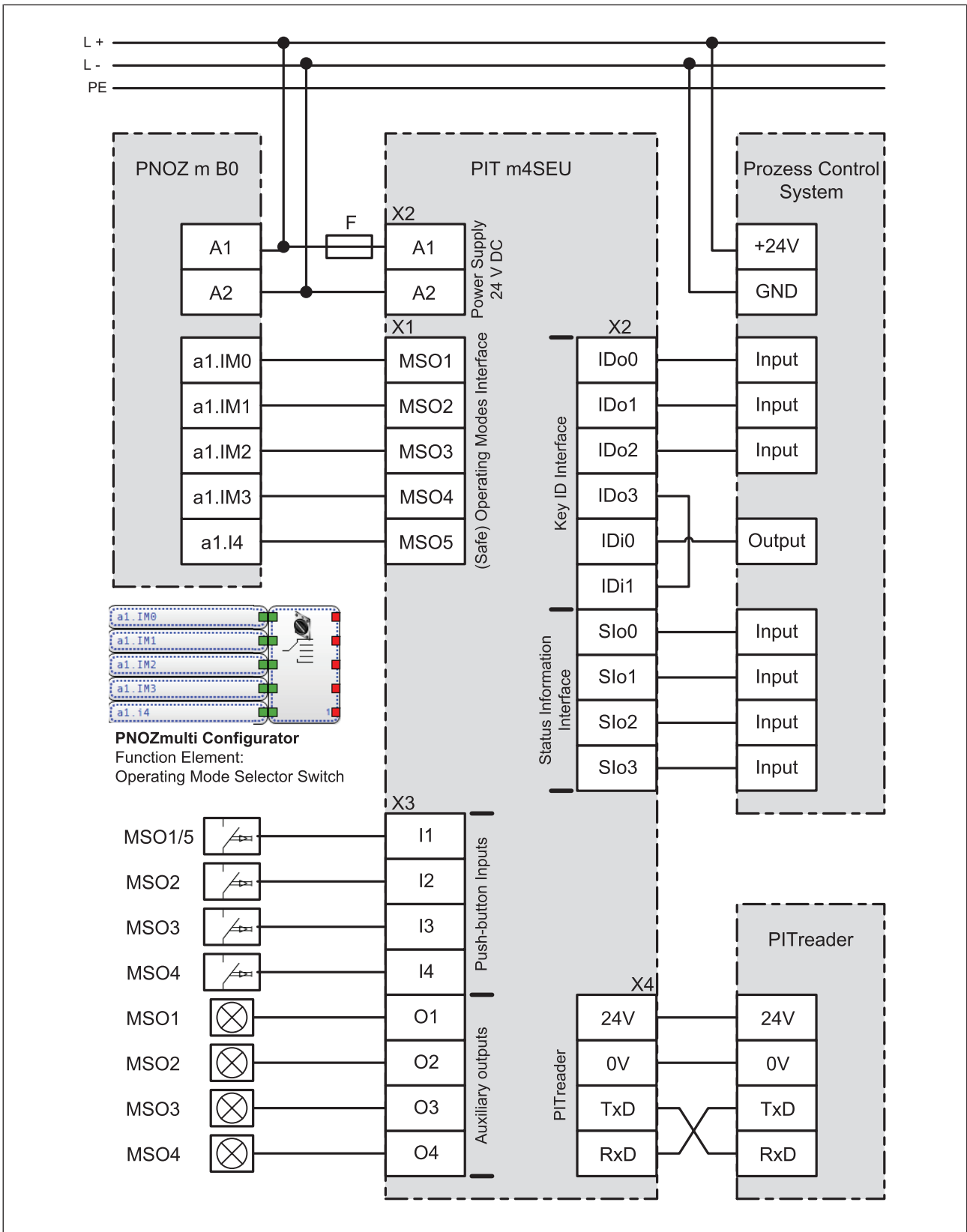

Fig.: Connection for handshake-controlled communication mode (example)

Connection for advanced communication mode

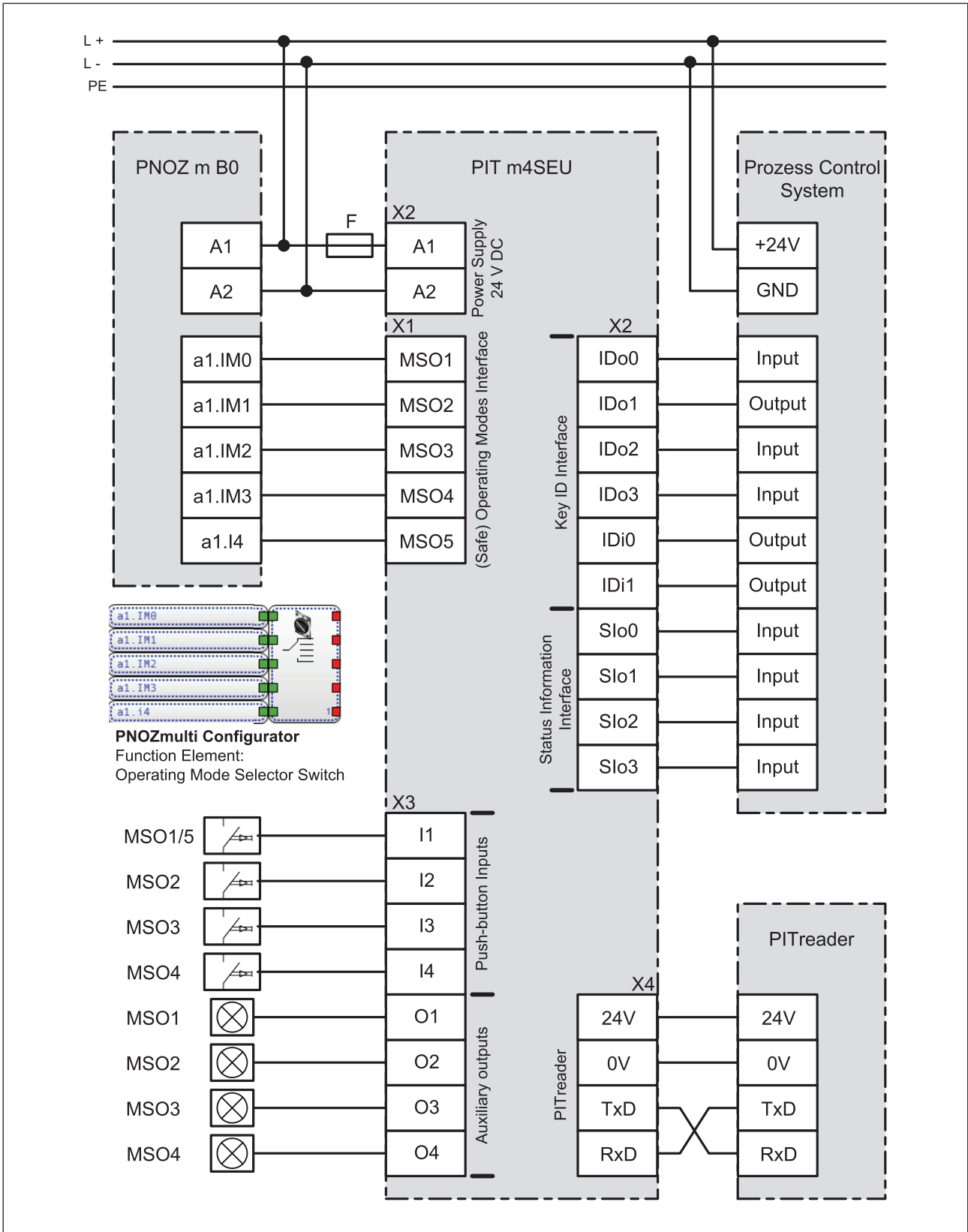

Fig.: Connection for advanced communication mode (example)

8 Operation

Switch-on behaviour



INFORMATION

After the PIT m4SEU is switched on (power-on) or after supply voltage is returned (reset), operating mode 1 or the most recently selected operating mode is selected automatically, depending on the device configuration. This also applies if no transponder is positioned or the transponder that is positioned is not identified correctly.

The corresponding display signal output is switched on simultaneously and the status interface Slo0 ... Slo3 displays the selected operating mode.

Behaviour in the event of an error at switch-on



NOTICE

In the event of an error, no active operating mode is displayed at the corresponding display element and no semiconductor output has a "1" signal.

Behaviour in the event of an error in operating modes 1 ... 4



NOTICE

In the event of an error, the device does **not** change operating mode. The active operating mode (1, 2, 3 or 4) is displayed on the relevant display element and the assigned semiconductor output has a "1" signal.

Behaviour in the event of an error in special operating mode 5 (Service)



NOTICE

In the event of an error, the device does **not** change operating mode. Faulty operation is indicated by the fact that all the display elements are either all lit or all out. The assigned semiconductor output has a "1" signal.

Requirements of the user



NOTICE

The user must check

- whether he has sufficient training and permission for the operating mode he has selected.
- that the operating mode displayed after the selection matches the operating mode he selected.
- that the expected operating mode is preselected after power-on.
- that the safety controller is displaying the activated operating mode correctly.

8.1 Select operating modes 1 ... 4

Prerequisites

- ▶ A transponder with the corresponding permission must be positioned in the read area of the PITreader.
- ▶ The PITreader must recognise the transponder as valid.
- ▶ The transponder must be positioned in the read area of the PITreader for the whole period that the pushbutton is operated.
- ▶ Several pushbuttons may **not** be operated simultaneously when selecting an operating mode.

Procedure

1. Establish the connection with the transponder
 - ⇒ Position a transponder in the read area of the PITreader.

Note: The transponder must have permission for the operating mode into which you wish to switch. The permission can be identified via the imprint on the transponder or via the (visualisation of the) display on the Key ID interface.
2. Select operating mode
 - ⇒ Select the operating mode you want by pressing the relevant button. Please note the required operating time (see [Monitoring of operating time](#) [📖 57]). The operating mode has been selected correctly if the corresponding display element is lit once the pushbutton is released.
3. Complete operating mode selection
 - ⇒ Complete the operating mode selection by removing the transponder. Once you have removed the transponder, the PIT m4SEU behaves in accordance with the configuration (see [Switching behaviour after permission is removed](#) [📖 21]).

**INFORMATION**

You can switch at will between the individual operating modes 1, 2, 3 and 4; i.e. it is possible to switch from operating mode 1 to operating mode 3 or from operating mode 4 to operating mode 2, for example.

8.2 Select special mode (service)

Prerequisites

- ▶ A transponder with permission for special operating mode 5 (Service) must be positioned in the read area of the PITreader.
- ▶ The PITreader must recognise the transponder as valid.
- ▶ The transponder must be positioned in the read area of the PITreader for the whole period that the pushbutton is operated.
- ▶ Several pushbuttons may **not** be operated simultaneously when selecting an operating mode.

Procedure

1. Establish the connection with the transponder
 - ⇒ Position the "Key Service" transponder in the read area of the PITreader.
2. Select special operating mode 5 (Service)
 - ⇒ Press pushbutton 1 (operating mode 1).
Please note the required operating time (see [Monitoring of operating time](#) [📖 57]). The operating mode has been selected correctly if all the display elements flash when pushbutton 1 is released. The display elements flash for as long as they are in special operating mode 5 (Service).
3. Complete operating mode selection
 - ⇒ Complete the operating mode selection by removing the transponder. Once you have removed the transponder, the PIT m4SEU behaves in accordance with the configuration (see [Switching behaviour after permission is removed](#) [📖 21]).

**INFORMATION**

Special operating mode 5 (Service) can be selected from any of the operating modes.

8.3 Monitoring of operating time

A switch to a different operation mode is only detected if the relevant pushbutton has been operated for a defined time period.

Pushbutton's operating time

| Input | Operating mode | Output | Operating time |
|-------|-------------------------------|--------|----------------------|
| I1 | Operating mode 1 | MSO1 | > 50 ms and < 5 s |
| I2 | Operating mode 2 | MSO2 | |
| I3 | Operating mode 3 | MSO3 | |
| I4 | Operating mode 4 | MSO4 | |
| I1 | Operating mode 5 (Service) | MSO5 | > 5 s and < 10 s |

8.4 Switchover time

Once a pushbutton has been released, the assigned output on the operating mode interface switches to a "1" signal after the reaction time t_2 has elapsed (see Technical details). A defined switchover time t_1 guarantees that only one operating mode at a time has a "1" signal at the assigned output.

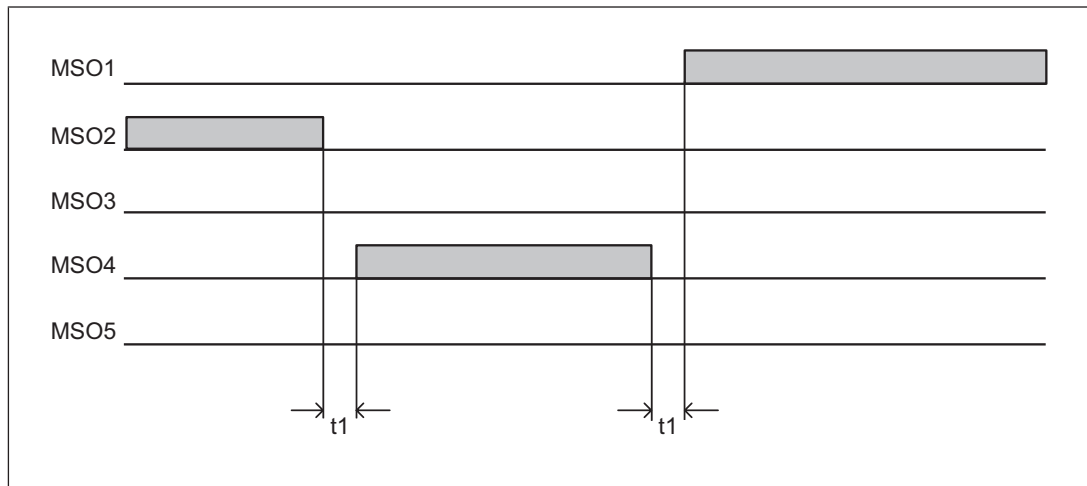

Fig.: Time behaviour when switching operating mode

8.5 Device status display

Two LEDs are available on the top of the device to display the device status.

| LED | Colour | State | Meaning |
|-------------|--------|-------|--|
| Power/Fault | Green | ☀ | Voltage supply connected, the device is in a RUN state |
| | Red | ☀ | The device is in a STOP state |
| Access | Yellow | ☀ | Valid permission has been transferred from the PITreader |

8.6 Troubleshooting

If an error occurs on the PIT m4SEU, the last operating mode to be set will be retained.

| Error | Possible cause | Remedy |
|-------------------------------------|---|---|
| Unable to switch the operating mode | Multiple pushbuttons operated | Make sure that only one button is operated. |
| | Operating time too long or too short | Make sure that the period of operation is observed. |
| | Transponder is not detected | Make sure that the transponder is positioned in the read area of the PITreader. |
| | No valid permission | Make sure that you use a transponder that has the required permission. Ensure that the PITreader interface is connected correctly. See also the PITreader operating manual. |
| Device error | <ul style="list-style-type: none"> - The DIP switch setting was changed during operation - Invalid configuration via the DIP switch setting | Delete error |

Please refer to the timing diagram for [Device error](#)  [26].

8.6.1 Delete error

Procedure:

- ▶ Switch off device (power off)
- ▶ Configure DIP switch setting as shown (all switches to ON)

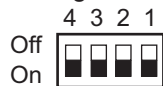



- ▶ Device restart → device error is still displayed
- ▶ Switch off device
- ▶ Configure required DIP switch position
- ▶ Device restart → Error deleted

8.7 Diagnostics

Status information is sent to the interface for status information (Slo0 ... Slo3) and to the PITreader.

8.7.1 Status information about the interface for status information





Various status information can be signalled via the interface for status information (see [Block diagram](#)  [15]). The status information can be evaluated through a control system (see [Interface for status information](#)  [22]).









































8.7.2 Status information about the signal outputs O1 ... O4

















Display elements can be connected to the signal outputs; these elements display which operating mode is active, i.e. which output (MSO1 ... MSO5) has a "1" signal.

Evaluation of the display elements

Legend

-  Display on
-  Display flashes with $T_i = 500$ ms, $T_p = 500$ ms
-  Display flashes 3 times with $T_i = 50$ ms, $T_p = 950$ ms
-  Display off

| Display for pushbutton 1 | Display for pushbutton 2 | Display for pushbutton 3 | Display for pushbutton 4 | Meaning |
|---|---|---|---|--|
|  |  |  |  | ▶ No supply voltage |
|  |  |  |  | ▶ Operating mode 5 (Service) is active ▶ MSO5 has a "1" signal |
|  |  |  |  | ▶ Operating mode 1 is active ▶ MSO1 has a "1" signal |
|  |  |  |  | ▶ Operating mode 2 is active ▶ MSO2 has a "1" signal |
|  |  |  |  | ▶ Operating mode 3 is active ▶ MSO3 has a "1" signal |
|  |  |  |  | ▶ Operating mode 4 is active ▶ MSO4 has a "1" signal |
|  |  * |  |  | ▶ No permission for operating mode 1 or ▶ Operating mode lock active |
|  * |  |  |  | ▶ No permission for operating mode 2 or ▶ Operating mode lock active |
|  * |  |  |  | ▶ No permission for operating mode 3 or ▶ Operating mode lock active |
|  * |  |  |  | ▶ No permission for operating mode 4 or ▶ Operating mode lock active |

| Display for pushbutton 1 | Display for pushbutton 2 | Display for pushbutton 3 | Display for pushbutton 4 | Meaning |
|---|---|---|---|---|
|  |  |  |  | <ul style="list-style-type: none"> ▶ Only when operating mode is preselected ▶ Operating mode 2 is preselected, but operating mode 1 is still active ▶ MSO1 has a "1" signal |
|  |  |  |  | <ul style="list-style-type: none"> ▶ Only when operating mode is preselected ▶ Operating mode 5 is preselected, but operating mode 1 is still active ▶ MSO1 has a "1" signal |
|   ** |   ** |   ** |   ** | <ul style="list-style-type: none"> ▶ Only when operating mode is preselected ▶ Operating mode 1 is preselected, but operating mode 5 is still active ▶ MSO5 has a "1" signal |

* Operating mode serves only as an example. One of the operating modes must always light or flash.

** Display element for the newly selected operating mode and all other display elements flash alternately

9 Technical details

Where standards are undated, the 2024-06 valid editions apply.

| General | |
|---|---|
| Certifications | CE, TÜV, UKCA, cULus Listed |
| Electrical data | |
| Supply voltage | |
| Voltage | 24 V |
| Kind | DC |
| Type of power supply | SELV/PELV |
| Voltage tolerance | -15 %/+20 % |
| Output of external power supply (DC) at no load | 3,5 W |
| External unit fuse protection F1 | 4 A, circuit breaker 24 V DC, characteristic B/C |
| Duty cycle | 100 % |
| Status indicator | LED |
| Inputs | |
| Number of safe inputs | 4 |
| Number of standard inputs | 3 |
| Signal level at g0 h | -3 - +5 V DC |
| Signal level at "1" | 15 - 30 V DC |
| Input current, safe inputs | 5 mA |
| Input current, standard inputs | 3 mA |
| Voltage at inputs | 24 V DC |
| Input current range | 5 mA |
| Galvanic isolation | No |
| Semiconductor outputs | |
| Overall performance ext. Load, semiconductor | 12 W |
| Number of positive-switching single-pole semiconductor outputs | 17 |
| Switching capability | |
| Voltage | 24 V |
| Current | 50 mA |
| Signal level at "1" | UB - 0.5 VDC |
| Residual current at "0" | 0,5 mA |
| Galvanic isolation | No |
| Short circuit-proof | Yes |
| Times | |
| Reaction time t | 1 s |
| Switch-on delay | |
| after UB is applied | 1 s |
| Supply interruption before de-energisation | 20 ms |
| Switchover time | 50 ms |
| Max. reaction time change of operating mode depending on the request t2 | 200 ms |

| Times | |
|--------------------------------------|--|
| Operating time pushbutton 1 ... 4 | 50 ms ... 5 s |
| Operating time, service pushbutton | 5 s ... 10 s |
| Environmental data | |
| Ambient temperature | |
| in accordance with the standard | EN 60068-2-14 |
| Temperature range | -20 - 60 °C |
| Storage temperature | |
| in accordance with the standard | EN 60068-2-1/-2 |
| Temperature range | -25 - 70 °C |
| Climatic suitability | |
| in accordance with the standard | EN 60068-2-78 |
| Humidity | 93 % r. h. at 40 °C |
| Condensation during operation | Not permitted |
| Max. operating height above SL | 2000 m |
| EMC | EN 61131-2 |
| Vibration | |
| in accordance with the standard | EN 60068-2-6 |
| Frequency | 5 - 8,4 Hz, 8,4 - 150 Hz |
| Amplitude | 3,5 mm |
| Acceleration | 1g |
| Shock stress | |
| in accordance with the standard | EN 60068-2-27 |
| Acceleration | 15g |
| Duration | 11 ms |
| Airgap creepage | |
| in accordance with the standard | EN 61131-2 |
| Overvoltage category | II |
| Pollution degree | 2 |
| Rated insulation voltage | 60 V |
| Rated impulse withstand voltage | 0,8 kV |
| Protection type | |
| in accordance with the standard | EN 60529 |
| Housing | IP20 |
| Terminals | IP20 |
| Mounting area (e.g. control cabinet) | IP54 |
| Mechanical data | |
| Mounting position | Any |
| DIN rail | |
| Top hat rail | 35 x 15 EN 50022, 35 x 7,5 EN 50022 |
| Max. cable length | 1000 m |
| Material | |
| Bottom | PC |
| Front | PC |
| Connection type | Spring-loaded terminal, plug-in |

| Mechanical data | |
|--|---|
| Mounting type | plug-in |
| Conductor cross section with spring-loaded terminals: Flexible with/without crimp connector | 0,2 - 2,5 mm ² , 24 - 12 AWG |
| Spring-loaded terminals: Terminal points per connection | 1 |
| Stripping length with spring-loaded terminals | 9 mm |
| Dimensions | |
| Height | 90,5 mm |
| Width | 90 mm |
| Depth | 25 mm |
| Weight | 83 g |

9.1 Safety characteristic data



NOTICE

You must comply with the safety characteristic data in order to achieve the required safety level for your plant/machine.

| Operating mode | EN ISO 13849-1 PL | EN ISO 13849-1 Category | EN IEC 61508 PFH [1/h] | EN/IEC 61508 SIL | EN/IEC 61508 PFD | EN ISO 13849-1 T _M [year] |
|----------------|----------------------|----------------------------|---------------------------|---------------------|---------------------|---|
| – | PL d | Cat. 3 | 6,49E-09 | SIL 2 | 3,99E-04 | 20 |

Explanatory notes for the safety-related characteristic data:

- ▶ T_M is the maximum mission time in accordance with EN ISO 13849-1. The value also applies as the retest interval in accordance with EN/IEC 61508-6.

All the units used within a safety function must be considered when calculating the safety characteristic data.

Safety-related architecture

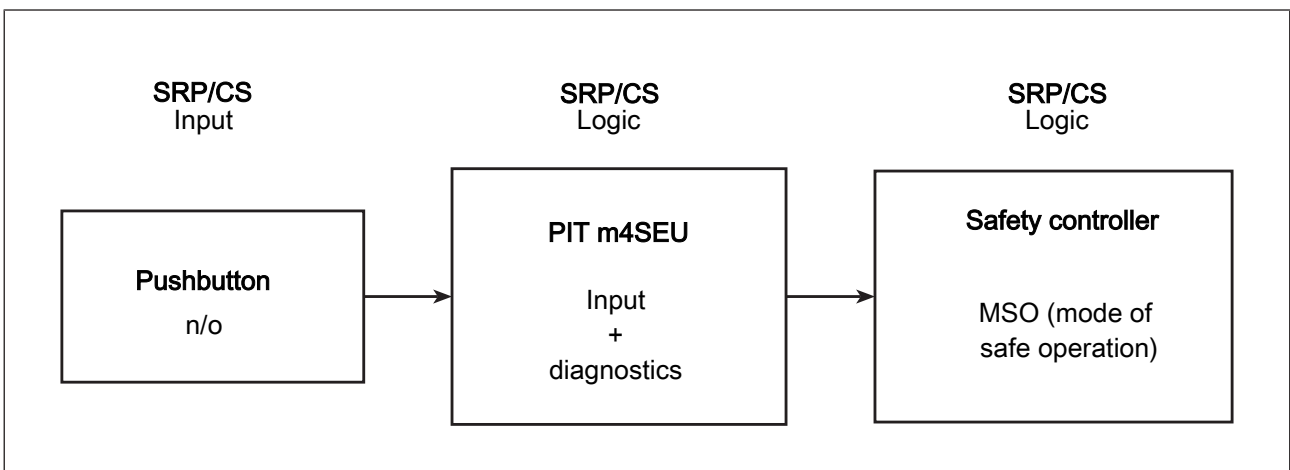



INFORMATION

In accordance with EN ISO 13849-1, the following parameters may be applied for the external pushbuttons with N/O contact:

- ▶ For the "operating mode selection" safety function it is sufficient for a safety level to be calculated for just one pushbutton.
- ▶ Cat. 2 can be estimated for the subsystem pushbutton; the following conditions are met:
 - Demand rate = Test rate (1 to 1) – Testing occurs immediately upon demand of the safety function and the overall time to detect the fault and to bring the machine to a non-hazardous condition is shorter than the time to reach the hazard.
 - $MTTF_{D,TE}$ (Test equipment) > $0.5 * MTTF_{D,L}$ (Logic)
- ▶ DC 90 % (shorts between contacts in the wiring are also detected)
- ▶ Measures against CCF (min. score of 65 in accordance with Table F.1 (EN ISO 13849-1) can be considered to have been fulfilled if the user can confirm that the items marked "Customer" have been fulfilled (see table below).

| No. | Measures against CCF | Score | Confirmed by |
|-----|--|-----------|--------------|
| 1 | Physical separation between signal paths, for example: <ul style="list-style-type: none"> ▶ separation in wiring/piping; ▶ detection of short circuits and open circuits in cables by dynamic test; ▶ separate shielding for the signal path of each channel; ▶ sufficient clearances and creepage distances on printed-circuit boards. | 15 | Pilz |
| 3.1 | Protection against over-voltage, over-pressure, over-current, over-temperature, etc. | 15 | Customer |
| 6.1 | For electric/electronic systems, prevention of contamination and electromagnetic disturbances (EMC) to protect against common cause failures in accordance with appropriate standards (e.g. IEC 61326-3-1). Fluidic systems: filtration of the pressure medium, prevention of dirt intake, drainage of compressed air, e.g. in compliance with the component manufacturers' requirements concerning purity of the pressure medium. NOTE: For combined fluidic and electric systems, both aspects should be considered. | 25 | Pilz |
| 6.2 | Other influences: Consideration of the requirements for immunity to all relevant environmental influences such as, temperature, shock, vibration, humidity (e.g. as specified in relevant standards). | 10 | Customer |
| | Total | 65 | |

Extract from Table F.1 (EN ISO 13849-1)

- ▶ The user must provide the following data:
 - The pushbutton must meet Cat. B

- To calculate the $MTTF_D$ of the pushbutton:
 - B_{10d} value
 - n_{op} (average number of operations per year) of the pushbutton



INFORMATION

A safety function's SIL/PL values are **not** identical to the SIL/PL values of the products used and may differ from these.



INFORMATION

The number of pushbutton operations n_{op} (average number of operations per year) is a maximum of half the operating mode changes that are anticipated because, as a maximum, the same pushbutton is operated only every second change of operating mode.

10 Order reference

10.1 Product

| Product type | Features | Order no. |
|--------------|------------------------------|-----------|
| PIT m4SEU | PITmode safe evaluation unit | 402250 |

10.2 Accessories

| Product type | Features | Order no. |
|------------------------------------|---|-----------|
| PIT m4SEU terminal set spring load | 1 set of spring-loaded terminals for PIT m4SEU (1 x 4-pin, 1 x 8-pin and 1 x 12-pin), straight cable outlet | 402306 |

10.2.1 Authentication system PITreader Key

| Product type | Features | Order no. |
|-------------------------|--|-----------|
| PITreader base unit | RFID authentication system Contents: Base unit, connector [402307] Required accessories: PITreader key adapter | 402255 |
| PITreader S base unit | RFID authentication system with extended function range, Contents: Base unit, connector [402307] Required accessories: PITreader key adapter | 402256 |
| PITreader key Adapter h | 1x PITreader key adapter horizontal + 1x nut for PITreader base unit | 402308 |

10.2.2 Authentication system PITreader Card

| Product type | Features | Order no. |
|-----------------------|--|-----------|
| PITreader card unit | RFID authentication system for cards, stickers & keys Contents: Base unit, connector [402307], PITreader card Adapter | 402320 |
| PITreader S card unit | RFID authentication system for cards, stickers & keys, with advanced function range Contents: Base unit, connector [402307], PITreader card Adapter | 402321 |

11 **EC declaration of conformity**

This product/these products meet the requirements of the directive 2006/42/EC on machinery of the European Parliament and of the Council. The complete EC Declaration of Conformity is available on the Internet at www.pilz.com/downloads.

Representative: Pilz GmbH & Co. KG, Felix-Wankel-Str. 2, 73760 Ostfildern, Germany

12 UKCA-Declaration of Conformity

This product(s) complies with following UK legislation: Supply of Machinery (Safety) Regulation 2008.

The complete UKCA Declaration of Conformity is available on the Internet at www.pilz.com/downloads.

Representative: Pilz Automation Technology, Pilz House, Little Colliers Field, Corby, Northamptonshire, NN18 8TJ United Kingdom, eMail: mail@pilz.co.uk

Support

Technical support is available from Pilz round the clock.

Americas

Brazil

+55 11 97569-2804

Canada

+1 888 315 7459

Mexico

+52 55 5572 1300

USA (toll-free)

+1 877-PILZUSA (745-9872)

Asia

China

+86 400-088-3566

Japan

+81 45 471-2281

South Korea

+82 31 778 3300

Australia and Oceania

Australia

+61 3 95600621

New Zealand

+64 9 6345350

Europe

Austria

+43 1 7986263-444

Belgium, Luxembourg

+32 9 3217570

France

+33 3 88104003

Germany

+49 711 3409-444

Ireland

+353 21 4804983

Italy, Malta

+39 0362 1826711

Scandinavia

+45 74436332

Spain

+34 938497433

Switzerland

+41 62 88979-32

The Netherlands

+31 347 320477

Türkiye

+90 216 5775552

United Kingdom

+44 1536 462203

You can reach our international hotline on:

+49 711 3409-222

support@pilz.com

Pilz develops environmentally-friendly products using ecological materials and energy-saving technologies. Offices and production facilities are ecologically designed, environmentally-aware and energy-saving. So Pilz offers sustainability, plus the security of using energy-efficient products and environmentally-friendly solutions.



We are represented internationally. Please refer to our homepage www.pilz.com for further details or contact our headquarters.

Headquarters: Pilz GmbH & Co. KG, Felix-Wankel-Straße 2, 73760 Ostfildern, Germany
Telephone: +49 711 3409-0, E-Mail: info@pilz.com, Internet: www.pilz.com

PILZ
THE SPIRIT OF SAFETY

CECE[®], CHRE[®], CMSE[®], INDUSTRIAL P[®], Leansafe[®], Myzei[®], PAS4000[®], PASscal[®], PASconfig[®], Pilz[®], PIT[®], PVMprimo[®], PVMprotego[®], PMCiendo[®], PMD[®], PME[®], PNOZ[®], Primo[®], PSEN[®], PSEN[®], PSS[®], PVIS[®], SafetyBUS p[®], SafetyNET p[®], THE SPIRIT OF SAFETY[®] are registered and protected trademarks of Pilz GmbH & Co. KG in some countries. We would point out that product features may vary from the details stated in this document, depending on the status at the time of publication and the scope of the equipment. We accept no responsibility for the validity, accuracy and entirety of the text and graphics presented in this information. Please contact our Technical Support if you have any questions.

1004648-EN-08, 2024-11 Printed in Germany
© Pilz GmbH & Co. KG, 2019