



## ▶ PIT oe ETH 5V

**PILZ**  
THE SPIRIT OF SAFETY

Operating Manual-1006785-EN-03  
- Control and signal devices



This document is the original document.

Where unavoidable, for reasons of readability, the masculine form has been selected when formulating this document. We do assure you that all persons are regarded without discrimination and on an equal basis.

All rights to this documentation are reserved by Pilz GmbH & Co. KG. Copies may be made for the user's internal purposes. Suggestions and comments for improving this documentation will be gratefully received.

Pilz®, PIT®, PMI®, PNOZ®, Primo®, PSEN®, PSS®, PVIS®, SafetyBUS p®, SafetyEYE®, SafetyNET p®, the spirit of safety® are registered and protected trademarks of Pilz GmbH & Co. KG in some countries.



SD means Secure Digital

<b>Introduction</b> .....	<b>4</b>
Validity of documentation .....	4
Using the documentation .....	4
Definition of symbols .....	4
<b>Overview</b> .....	<b>5</b>
Product features .....	5
Product view .....	5
<b>Safety</b> .....	<b>6</b>
Intended use .....	6
Safety regulations .....	6
Use of qualified personnel .....	6
Warranty and liability .....	7
Disposal .....	7
<b>Function description</b> .....	<b>7</b>
Block diagram .....	7
Operating states .....	8
<b>Installation and removal</b> .....	<b>9</b>
Dimensions in mm .....	11
<b>Wiring</b> .....	<b>12</b>
General wiring guidelines .....	12
Terminal configuration .....	13
Application example .....	14
<b>Maintenance and testing</b> .....	<b>14</b>
<b>Technical details</b> .....	<b>15</b>
<b>Order reference</b> .....	<b>16</b>
Product .....	16
Accessories .....	16

## Introduction

### Validity of documentation

This documentation is valid for the product PIT oe ETH 5V. It is valid until new documentation is published.

This operating manual explains the function and operation, describes the installation and provides guidelines on how to connect the product.

### Using the documentation

This document is intended for instruction. Only install and commission the product if you have read and understood this document. The document should be retained for future reference.

### Definition of symbols

Information that is particularly important is identified as follows:



#### **DANGER!**

This warning must be heeded! It warns of a hazardous situation that poses an immediate threat of serious injury and death and indicates preventive measures that can be taken.



#### **WARNING!**

This warning must be heeded! It warns of a hazardous situation that could lead to serious injury and death and indicates preventive measures that can be taken.



#### **CAUTION!**

This refers to a hazard that can lead to a less serious or minor injury plus material damage, and also provides information on preventive measures that can be taken.



#### **NOTICE**

This describes a situation in which the product or devices could be damaged and also provides information on preventive measures that can be taken. It also highlights areas within the text that are of particular importance.



**INFORMATION**

This gives advice on applications and provides information on special features.

**Overview**

**Product features**

- ▶ Activatable Ethernet interface
- ▶ Protective cap to protect against contamination, protection class IP65
- ▶ For mounting cutouts D22 (diameter 22.3 mm +0.4 mm/-0.0 mm) in accordance with EN 60947-5-1 with anti-rotation device

**Product view**

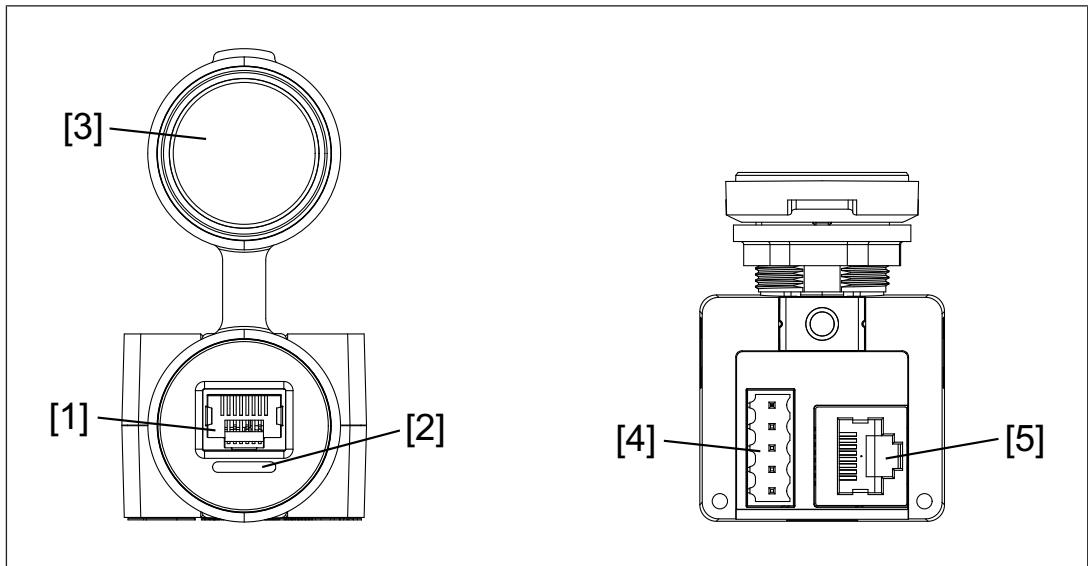

**Legend**

- [1] Activatable Ethernet interface
- [2] LED display
- [3] Protective cap
- [4] Plug-in terminal block
- [5] Ethernet interface

## Safety

### Intended use

The PIT oe ETH 5V is an activatable Ethernet interface, which can be used to establish or interrupt a connection in a network. Any controller or an authentication system such as PITreader can be used for activation.

### Improper use

The following is deemed improper use in particular:

- ▶ Any component, technical or electrical modification to the product,
- ▶ Use of the product outside the areas described in this operating manual,
- ▶ Use of the product outside the technical details (see chapter entitled [Technical Details](#) [ 15]).



#### NOTICE

##### EMC-compliant electrical installation

The product is designed for use in an industrial environment. The product may cause interference if installed in other environments. If installed in other environments, measures should be taken to comply with the applicable standards and directives for the respective installation site with regard to interference.

## Safety regulations

### Use of qualified personnel

The products may only be assembled, installed, programmed, commissioned, operated, de-commissioned and maintained by persons who are competent to do so.

A competent person is a qualified and knowledgeable person who, because of their training, experience and current professional activity, has the specialist knowledge required. In order to inspect, assess and handle products, devices, systems, plant and machinery, this person must be familiar with the state of the art and the applicable national, European and international laws, directives and standards.

It is the company's responsibility only to employ personnel who

- ▶ Are familiar with the basic regulations concerning health and safety / accident prevention,
- ▶ Have read and understood the information provided in the section entitled Safety
- ▶ Have a good knowledge of the generic and specialist standards applicable to the specific application.

### Warranty and liability

All claims to warranty and liability will be rendered invalid if

- ▶ The product was used contrary to the purpose for which it is intended,
- ▶ Damage can be attributed to not having followed the guidelines in the manual,
- ▶ Operating personnel are not suitably qualified,
- ▶ Any type of modification has been made (e.g. exchanging components on the PCB boards, soldering work etc.).

### Disposal

- ▶ When decommissioning, please comply with local regulations regarding the disposal of electronic devices, such as the Electrical and Electronic Equipment Act.

### Function description

The PIT oe ETH 5V is an activatable Ethernet interface, which can be used to establish or interrupt a connection in a network.

The Ethernet interface is activated when there is a high signal (5 V) at both inputs.

### Block diagram

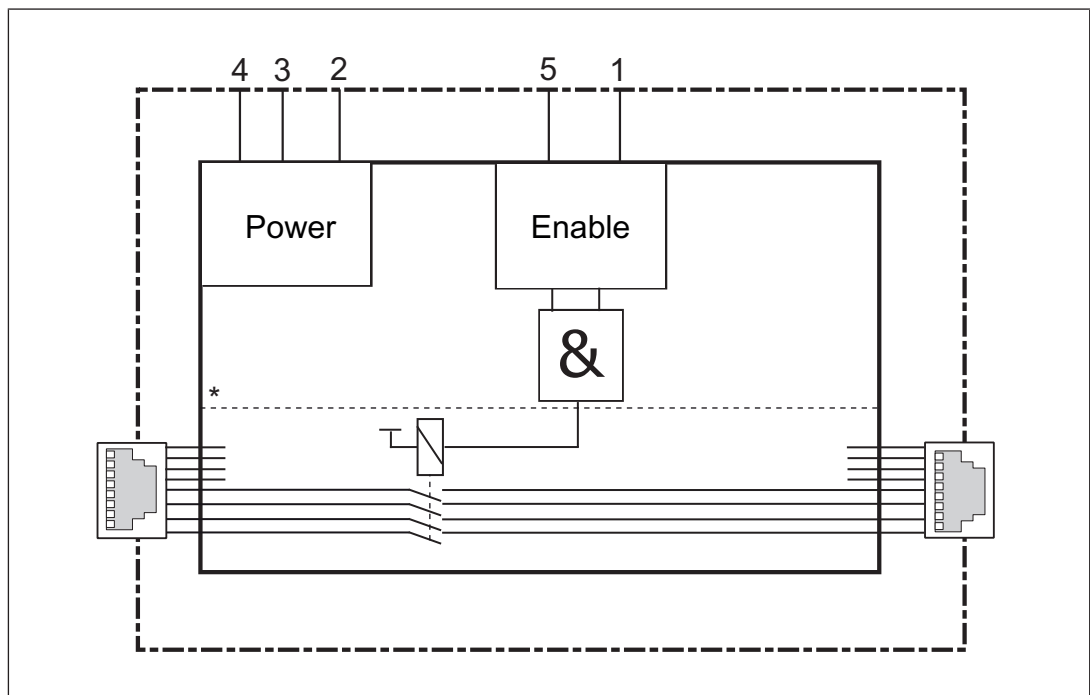

\* Galvanic isolation

### Operating states

The PIT oe ETH 5V signals its operating states via the LED display.

#### Legend



LED on



LED off

X Not relevant

Enable 1	Enable 2	Ethernet Link/Traffic	LED	State
0	0	0	●	Deactivated, data cannot be transferred via the network connection.
0	1	0		
1	0	0		
X	X	X		Supply voltage was applied (Lifesign).
1	1	0		Activated, data can be transferred. No signals/link detected.
1	1	1		Activated, data can be transferred. Signals/link detected.
0	0	1		Deactivated, nevertheless signals/link detected, network connection was not interrupted.
0	1	1		
1	0	1		
1	1	X		When first activated after the supply voltage is applied, the yellow LED lights up yellow, while a maintenance interval runs internally (approx. 3 seconds).

The LED display indicates the link/data signals with a 100 Mbit/s connection, provided the max. cable length (see [Technical details](#) 15) is not exceeded. Irrespective of that, the data is transferred up to a cable length of max. 60 m.

With a 10 Mbit/s connection, the link is not displayed via the LED; only the data transfer is displayed.

Diagnostics via the LED is possible when there is compliance with the max. cable length and an ambient temperature of up to 50 °C. With higher temperatures, the max. cable length is reduced.

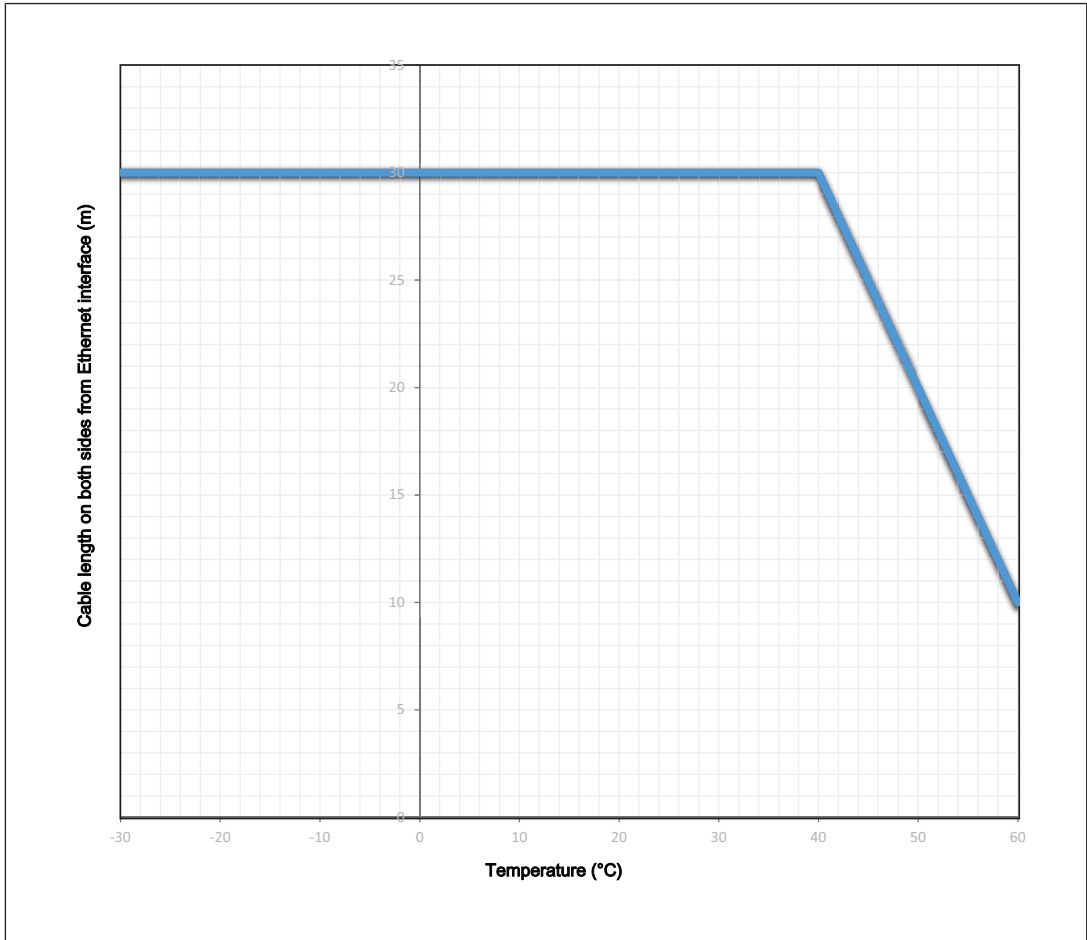

## Installation and removal

### Installation

- ▶ Install the product in the front panel of a control cabinet or in a control console.  
Material thickness: 2 ... 6 mm.
- ▶ Provide the front panel of the control cabinet or control console with a mounting cutout (Ø 22.3 mm +0.4 mm/-0.0 mm, D22 in accordance with EN 60947-5-1) and give the cutout a recess for the latch (to protect against twisting):

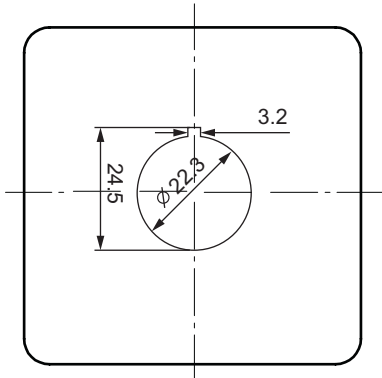

- ▶ Align the sealing cap in the required direction.

- ▶ Guide the upper section of the PIT oe ETH 5V into the mounting cutout and fasten it from the other side using the plastic nut (M22). Note the torque setting of 1.3 ... 2.1 Nm. We recommend that you use the installation wrench "PIT es wrench" to fasten the plastic nut (see [Order reference](#)  16]).
- ▶ Place the housing of the PIT oe ETH 5V on to the upper section until it locks in position.

### Removal

To remove the device, press both buttons on the side of the housing while pulling gently on the lower section.

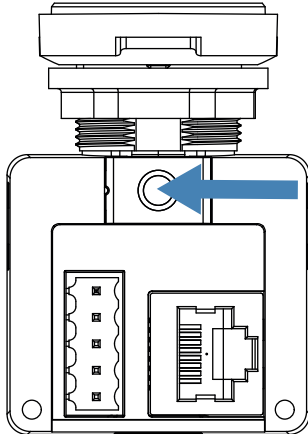

Dimensions in mm

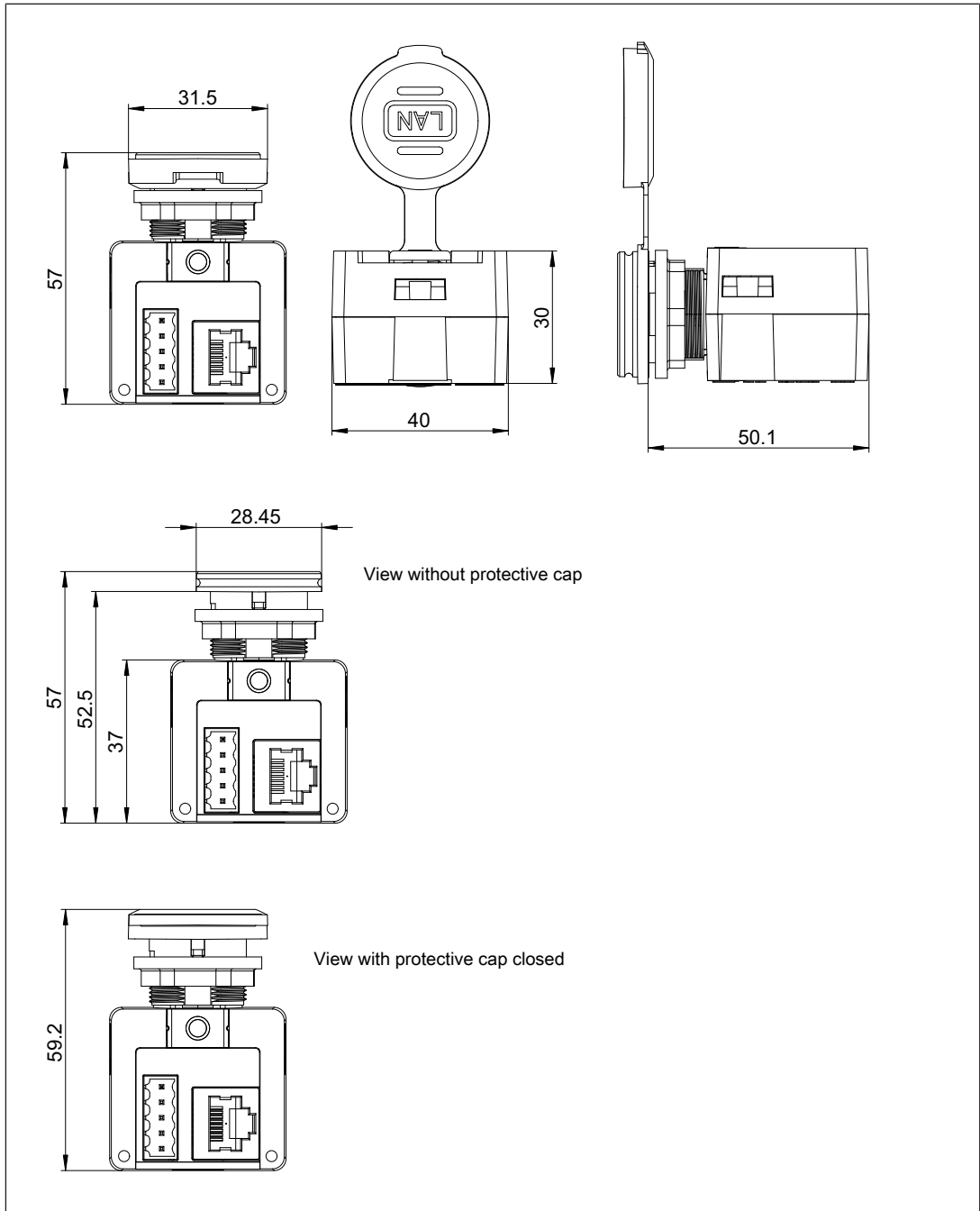

## Wiring

### General wiring guidelines

**NOTICE**

The PIT oe ETH 5V may only be connected to cables that are supplied via SELV/PELV power supplies. The power supply must meet the regulations for extra low voltages with protective separation (SELV, PELV).

**NOTICE**

Guideline for UL certification:

The device shall be supplied from an isolating transformer having a secondary Listed fuse rated either:

- max 5 amps for voltages 0~20 V (0~28.3 Vp), or
- 100/Vp for voltages of 20~30 V (28.3~42.4 Vp).

- ▶ Comply with the max. cable length (see [Technical details \[📖 15\]](#)).
- ▶ Only use shielded Ethernet cable (Cat5e S/FTP or better). The shield must be connected to earth on both sides.
- ▶ If it takes too long to establish the connection via Auto Negotiation, we recommend you go to the Ethernet settings and enter the following setting for all network subscribers:
  - Property: Speed & Duplex
  - Value: 100 Mbps Full Duplex

### Terminal configuration

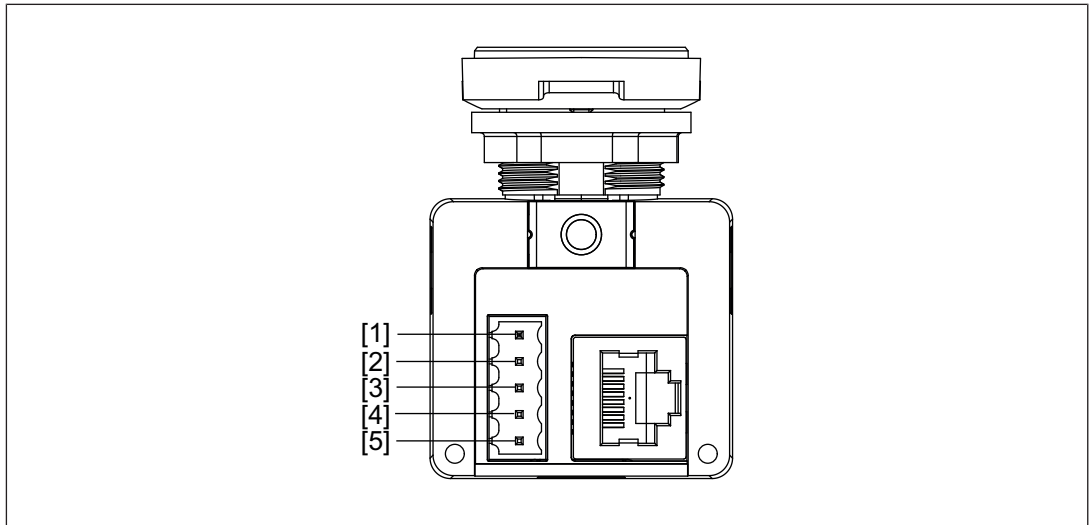

### Legend

- 1 Enable 1
- 2 GND
- 3 5 V
- 4 FE
- 5 Enable 2

### Application example

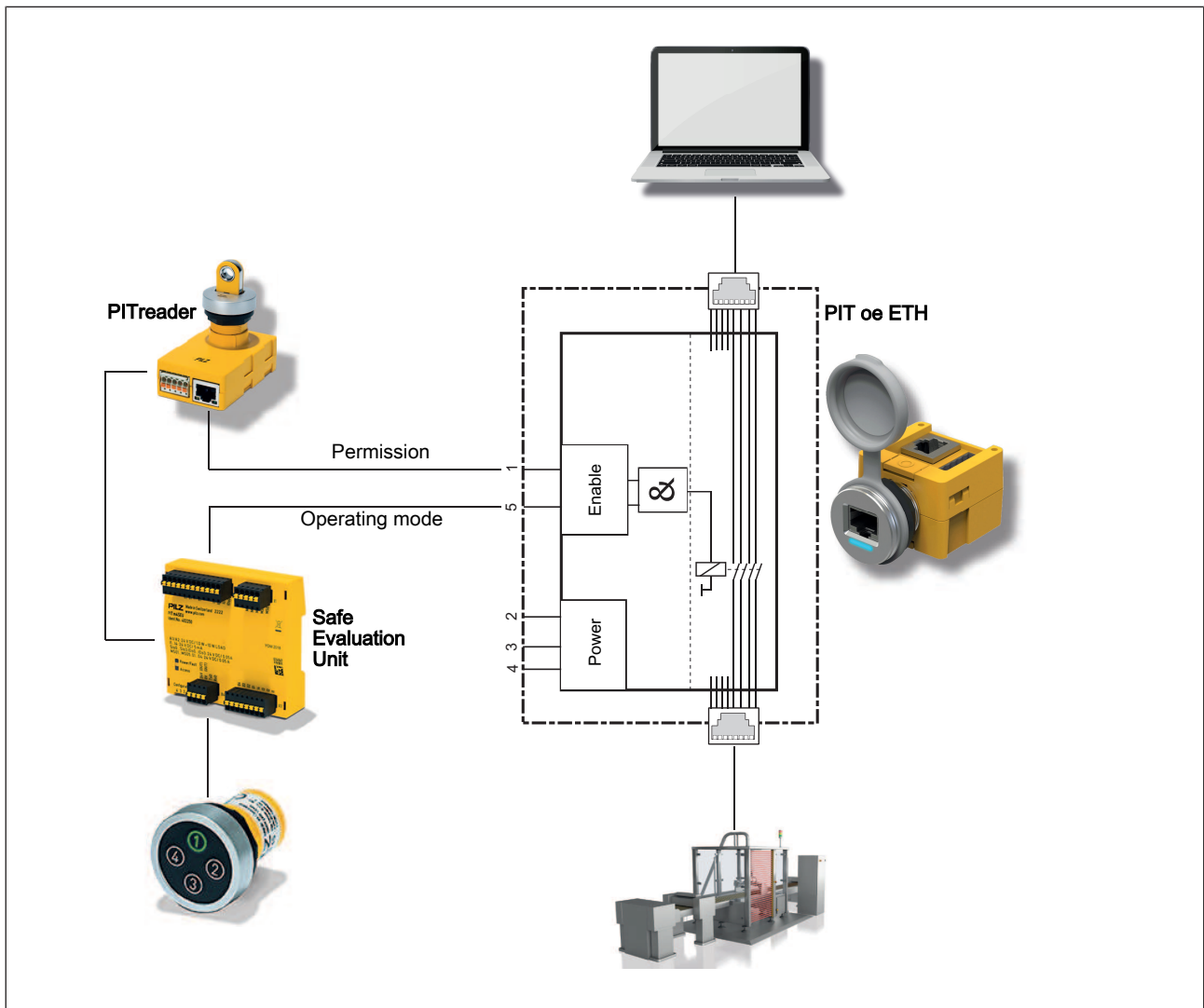

### Maintenance and testing

It is not necessary to perform maintenance work on the product in normal operation.

- ▶ Please return any faulty product to Pilz.

## Technical details

Where standards are undated, the 2013-08 valid editions apply.

<b>General</b>	
Certifications	<b>CE, UKCA, UL Recognized Component</b>
<b>Electrical data</b>	
Supply voltage	
Voltage	<b>5 V</b>
Kind	<b>DC</b>
Voltage tolerance	<b>-10 %/+10 %</b>
Output of external power supply (DC)	<b>0,3 W</b>
Duty cycle	<b>100 %</b>
Status indicator	<b>LED</b>
<b>Inputs</b>	
Quantity	<b>2</b>
Voltage at inputs	<b>5 V</b>
Input current at rated voltage	<b>1 mA</b>
Min. threshold voltage when signal changes from "1" to "0"	<b>1,5 V</b>
Max. threshold voltage when signal changes from "0" to "1"	<b>2 V</b>
<b>Ethernet interface</b>	
Quantity	<b>2</b>
Connection type	<b>RJ45</b>
Transmission rate	<b>10/100 Mbit/s</b>
<b>Environmental data</b>	
Climatic suitability	<b>EN 60068-2-2</b>
Ambient temperature	
Temperature range	<b>-20 - 60 °C</b>
Storage temperature	
Temperature range	<b>-40 - 85 °C</b>
Climatic suitability	
in accordance with the standard	<b>EN 60068-2-78</b>
Humidity	<b>93 % r. h. at 40 °C</b>
Condensation during operation	<b>Not permitted</b>
EMC	<b>EN 61131-2 (Zone B)</b>
Vibration	
in accordance with the standard	<b>EN 60068-2-6</b>
Frequency	<b>5 - 55 Hz</b>
Airgap creepage	
in accordance with the standard	<b>EN 61131-2</b>
Overvoltage category	<b>II</b>
Pollution degree	<b>2</b>

**Environmental data**

## Protection type

Housing	<b>IP20</b>
in accordance with UL	<b>Type 1 Enclosure</b>
Mounting area (e.g. control cabinet)	<b>IP65</b>

**Mechanical data**

## Mounting position

**Any**

## Max. cable length

**30 m**

## Connection type

**Spring-loaded terminal, plug-in**

## Max. torque setting for fixing nuts

**1,3 - 2,1 Nm**

## Conductor cross section with spring-loaded terminals:

## Flexible with/without crimp connector

**0,08 - 1,5 mm<sup>2</sup>, 28 - 16 AWG**

## Dimensions

Height	<b>40 mm</b>
Width	<b>30 mm</b>
Depth	<b>59,2 mm</b>

## Weight

**42 g****Order reference****Product**

<b>Product type</b>	<b>Features</b>	<b>Order no.</b>
PIT oe ETH 5V	Activatable Ethernet interface (RJ45), supply and input voltage 5 V	402315

**Accessories**

<b>Product type</b>	<b>Features</b>	<b>Order no.</b>
PIT es wrench	Installation wrench for PIT es pushbutton	400222
PIT oe DIN rail adapter	DIN top hat rail adapter for control elements PIToe (PIT oe ETH)	402325

# ► Support

Technical support is available from Pilz round the clock.

## Americas

### Brazil

+55 11 97569-2804

### Canada

+1 888 315 7459

### Mexico

+52 55 5572 1300

### USA (toll-free)

+1 877-PILZUSA (745-9872)

## Asia

### China

+86 400-088-3566

### Japan

+81 45 471-2281

### South Korea

+82 31 778 3300

## Australia and Oceania

### Australia

+61 3 95600621

### New Zealand

+64 9 6345350

## Europe

### Austria

+43 1 7986263-444

### Belgium, Luxembourg

+32 9 3217570

### France

+33 3 88104003

### Germany

+49 711 3409-444

### Ireland

+353 21 4804983

### Italy, Malta

+39 0362 1826711

## Scandinavia

+45 74436332

## Spain

+34 938497433

## Switzerland

+41 62 88979-32

## The Netherlands

+31 347 320477

## Türkiye

+90 216 5775552

## United Kingdom

+44 1536 462203

## You can reach our international hotline on:

+49 711 3409-222

support@pilz.com

Pilz develops environmentally-friendly products using ecological materials and energy-saving technologies. Offices and production facilities are ecologically designed, environmentally-aware and energy-saving. So Pilz offers sustainability, plus the security of using energy-efficient products and environmentally-friendly solutions.



CECE<sup>®</sup>, CHRE<sup>®</sup>, CMSE<sup>®</sup>, INDUSTRIAL P<sup>®</sup>, Leansafe<sup>®</sup>, Myzel<sup>®</sup>, PAS4000<sup>®</sup>, PASscal<sup>®</sup>, PASconfig<sup>®</sup>, Pilz<sup>®</sup>, PIT<sup>®</sup>, PMSprimo<sup>®</sup>, PMSprotego<sup>®</sup>, PMCiendo<sup>®</sup>, PMD<sup>®</sup>, PMI<sup>®</sup>, PNOZ<sup>®</sup>, Primo<sup>®</sup>, PSEN<sup>®</sup>, PSS<sup>®</sup>, PVS<sup>®</sup>, SafetyBUS p<sup>®</sup>, SafetyNET p<sup>®</sup>, THE SPIRIT OF SAFETY<sup>®</sup> are registered and protected trademarks of Pilz GmbH & Co. KG in some countries. We would point out that product features may vary from the details stated in this document, depending on the status at the time of publication and the scope of the equipment. We accept no responsibility for the validity, accuracy and entirety of the text and graphics presented in this information. Please contact our Technical Support if you have any questions.

1006785-EN-03, 2025-04 Printed in Germany  
© Pilz GmbH & Co. KG, 2019

We are represented internationally. Please refer to our homepage [www.pilz.com](http://www.pilz.com) for further details or contact our headquarters.

Headquarters: Pilz GmbH & Co. KG, Felix-Wankel-Straße 2, 73760 Ostfildern, Germany  
Telephone: +49 711 3409-0, E-Mail: [info@pilz.com](mailto:info@pilz.com), Internet: [www.pilz.com](http://www.pilz.com)

**PILZ**  
THE SPIRIT OF SAFETY