



# Solenoid Driver

## KFD2-SLD-Ex2.1545-Y1

- 2-channel isolated barrier
- 24 V DC supply (bus or loop powered)
- Output 45 mA at 15 V DC
- Line fault transparency (LFT)
- Test pulse immunity



### Function

This isolated barrier is used for intrinsic safety applications. The device supplies power to solenoids, LEDs and audible alarms located in the explosion-hazardous area. The device is controlled with a loop powered signal or a bus powered logic signal. The device is immune to the test pulses of various control systems. The device simulates a minimum load at the input. The minimum load is set via the mode of operation. In the loop-powered mode of operation, a minimum load of 20 mA is simulated. In the bus-powered mode of operation, a minimum load of 5 mA is simulated. The line fault transparency function can display a line fault in the field by a change in impedance at the switching input of the solenoid driver. A fault is indicated by LEDs and output via a fault indication output.

### Connection

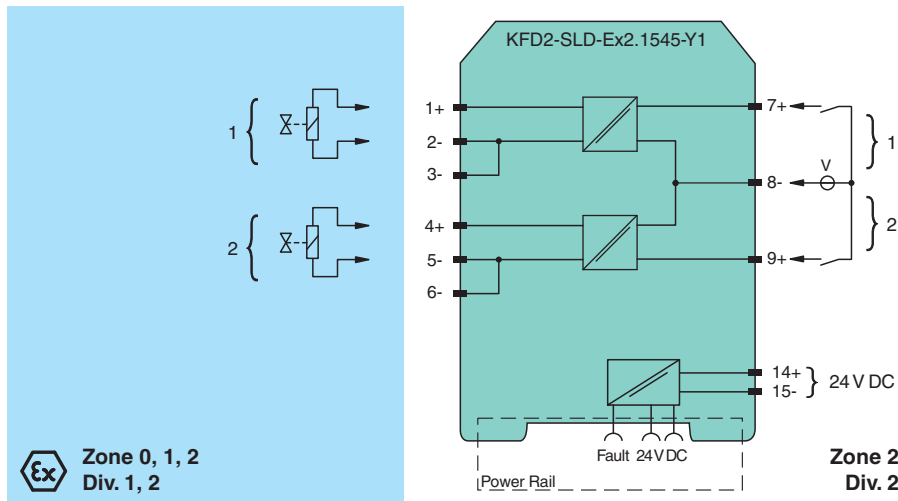

### Technical Data

General specifications	
Signal type	Digital Output
<b>Supply</b>	
Connection	Power Rail or terminals 14+, 15-
Rated voltage	$U_r$ 18 ... 30 V DC
Power consumption	max. 3.5 W at 45 mA output current
<b>Input</b>	
Connection side	control side
Connection	terminals 7, 8, 9
Test pulse length	max. 2 ms from DO card

Release date: 2024-08-05 Date of issue: 2024-08-05 Filename: 70178496\_eng.pdf

Refer to "General Notes Relating to Pepperl+Fuchs Product Information".

Pepperl+Fuchs Group  
www.pepperl-fuchs.com

USA: +1 330 486 0002  
pa-info@us.pepperl-fuchs.com

Germany: +49 621 776 2222  
pa-info@de.pepperl-fuchs.com

Singapore: +65 6779 9091  
pa-info@sg.pepperl-fuchs.com

**PF** PEPPERL+FUCHS

## Technical Data

Signal level		loop powered 1-signal: 18 ... 30 V DC 0-signal: 0 ... 5 V DC bus powered 1-signal: 15 ... 30 V DC (current limited to 5 mA) 0-signal: 0 ... 5 V DC
Rated current	$I_r$	0-signal: typ. 1.6 mA at 1.5 V DC; typ. 8 mA at 3 V DC (maximum leakage current DO card) 1-signal: $\geq 20$ mA (minimum load current DO card)
Inrush current		$\leq 200$ mA after 100 $\mu$ s
<b>Output</b>		
Connection side		field side
Connection		channel 1: terminals 1+, 2-, 3- channel 2: terminals 4+, 5-, 6-
Internal resistor	$R_i$	approx. 167 $\Omega$
Current	$I_e$	45 mA
Voltage	$U_e$	$\geq 15$ V
Current limit	$I_{max}$	45 mA
Open loop voltage	$U_s$	min. 23.6 V
Load		nominal 0.05 ... 20 k $\Omega$ , valid range for line fault detection (LFD)
Energized/De-energized delay		$\leq 20$ ms / $\leq 20$ ms
Line fault detection		
Test current		max. 350 $\mu$ A , calculated by $I_{LFD} = 3.3 \text{ V} / (10 \text{ k}\Omega + R_{Load})$
<b>Galvanic isolation</b>		
Input/Output		reinforced insulation according to IEC/EN 61010-1, rated insulation voltage 300 V <sub>eff</sub>
Power supply/Output		reinforced insulation according to IEC/EN 61010-1, rated insulation voltage 300 V <sub>eff</sub>
<b>Indicators/settings</b>		
Display elements		LEDs
Control elements		DIP switch
Configuration		via DIP switches
Labeling		space for labeling at the front
<b>Directive conformity</b>		
Electromagnetic compatibility		
Directive 2014/30/EU		EN 61326-1:2013 (industrial locations)
<b>Conformity</b>		
Electromagnetic compatibility		NE 21:2017 , EN IEC 61326-1:2021 (industrial locations) , EN IEC 61326-3-2:2018 For further information see system description.
<b>Ambient conditions</b>		
Ambient temperature		-40 ... 70 °C (-40 ... 158 °F) , both channels configured in the <b>bus powered</b> mode of operation -40 ... 60 °C (-40 ... 140 °F) , all other configurations extended ambient temperature range up to 70 °C (158 °F) for other configurations, refer to manual for necessary mounting conditions
<b>Mechanical specifications</b>		
Degree of protection		IP20
Connection		screw terminals
Mass		approx. 150 g
Dimensions		20 x 119 x 115 mm (0.8 x 4.7 x 4.5 inch) (W x H x D) , housing type B2
Mounting		on 35 mm DIN mounting rail acc. to EN 60715:2001
<b>Data for application in connection with hazardous areas</b>		
EU-type examination certificate		FIDI 21 ATEX 0091 X
Marking		Ⓜ II 3(1)G Ex ec [ia Ga] IIC T4 Gc Ⓜ II (1)D [Ex ia Da] IIIC Ⓜ I (M1) [Ex ia Ma] I
Output		Ex ia Refer to certificate for alternative parameters.
Voltage	$U_o$	25.2 V
Current	$I_o$	52 mA
Power	$P_o$	850 mW (angular characteristic curve)

Release date: 2024-08-05 Date of issue: 2024-08-05 Filename: 70178496\_eng.pdf

Refer to "General Notes Relating to Pepperl+Fuchs Product Information".

Pepperl+Fuchs Group  
www.pepperl-fuchs.comUSA: +1 330 486 0002  
pa-info@us.pepperl-fuchs.comGermany: +49 621 776 2222  
pa-info@de.pepperl-fuchs.comSingapore: +65 6779 9091  
pa-info@sg.pepperl-fuchs.com

**PEPPERL+FUCHS**

**Technical Data**

Internal resistance	R <sub>i</sub>	167 Ω
Supply		
Maximum safe voltage	U <sub>m</sub>	250 V (Attention! The rated voltage can be lower.)
Input		
Maximum safe voltage	U <sub>m</sub>	250 V (Attention! The rated voltage can be lower.)
Collective error message		
Maximum safe voltage	U <sub>m</sub>	250 V (Attention! The rated voltage can be lower.)
Galvanic isolation		
Input/Output		safe electrical isolation acc. to IEC/EN 60079-11, rated insulation voltage 300 V <sub>rms</sub>
Output/power supply		safe electrical isolation acc. to IEC/EN 60079-11, rated insulation voltage 300 V <sub>rms</sub>
Directive conformity		
Directive 2014/34/EU		EN IEC 60079-0:2018+AC:2020 , EN 60079-7:2015+A1:2018 , EN 60079-11:2012
<b>International approvals</b>		
UL approval		E106378
Control drawing		116-0488
IECEX approval		
IECEX certificate		IECEX FIDI 21.0009X
IECEX marking		Ex ec [ia Ga] IIC T4 Gc [Ex ia Da] IIC [Ex ia Ma] I
<b>General information</b>		
Supplementary information		Observe the certificates, declarations of conformity, instruction manuals, and manuals where applicable. For information see <a href="http://www.pepperl-fuchs.com">www.pepperl-fuchs.com</a> .

**Assembly**

Front view

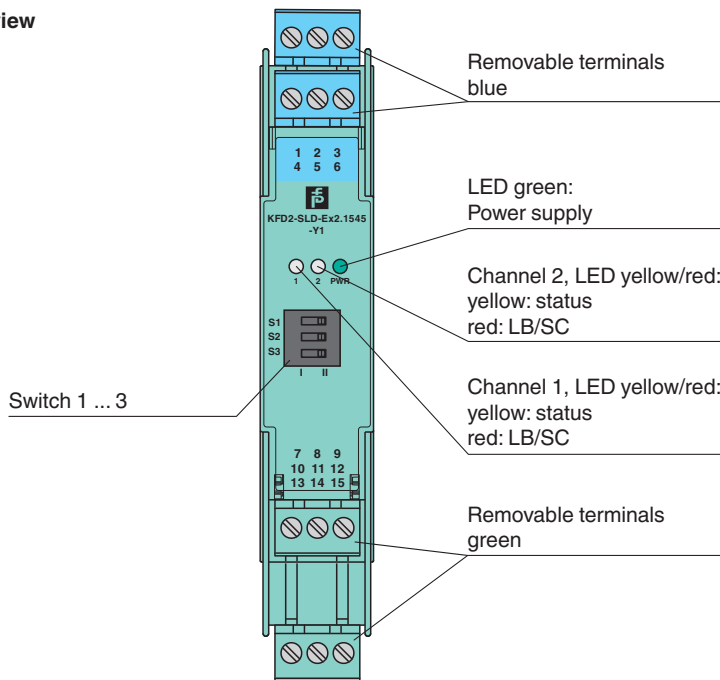

Release date: 2024-08-05 Date of issue: 2024-08-05 Filename: 70178496\_eng.pdf

**Configuration**

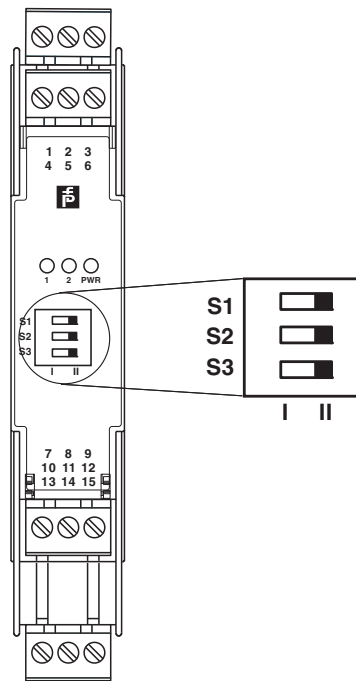

**Switch settings**

Switch	Function		Position
S1	Line fault transparency (LFT)	enabled	I
		disabled	II
S2	Mode of operation channel 1	loop powered	I
		bus powered	II
S3	Mode of operation channel 2	loop powered	I
		bus powered	II

Factory setting: line fault detection enabled, mode of operation loop powered

**Characteristic Curve**

**Output characteristics**

**Output circuit diagram**

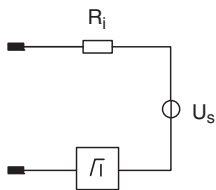

**Output characteristic**

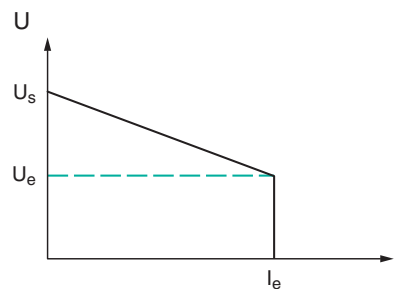

Release date: 2024-08-05 Date of issue: 2024-08-05 Filename: 70178496\_eng.pdf