

Contents

	Page
1 2D Views	2
2 Configuration settings	3
3 Attachments / Technical document	4
4 Contact information	5

1 2D Views

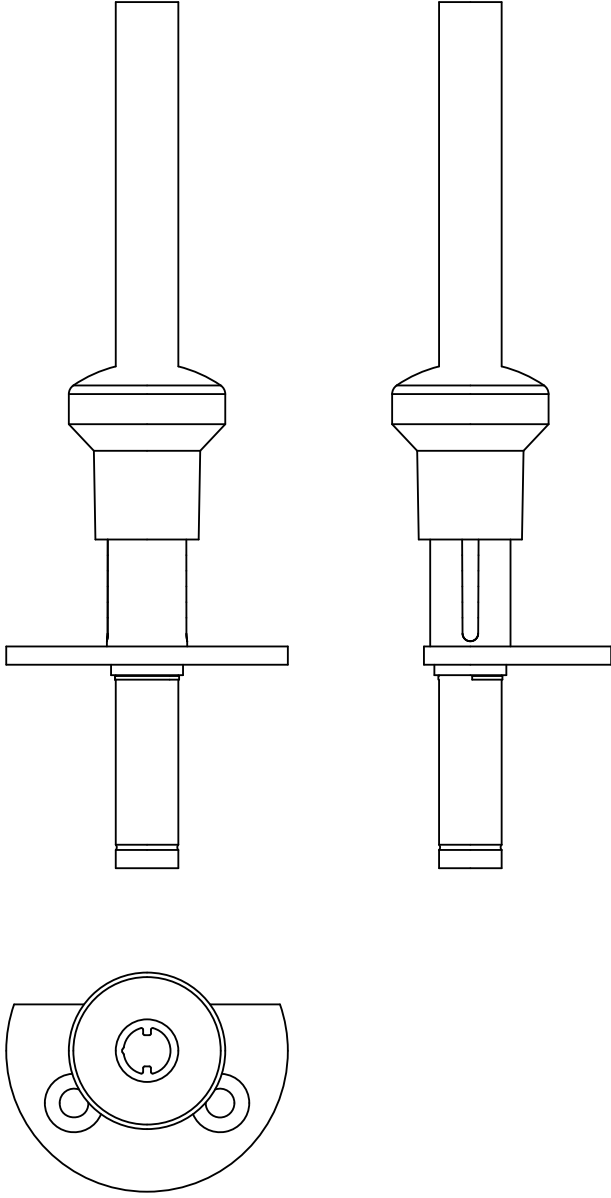







2 Configuration settings

Configuration	
Selection	Type
Type	ACC-AZM40PT-T-40MM
Push button	Unactuated
Adapter extension length	36

Bill of Materials Data	
Manufacturer	K.A. Schmersal GmbH & Co. KG
Description	Emergency exit with push button ACC-AZM40PT-T-40MM
Part number	103054271
Selection	ACC-AZM40PT-T-40MM

3 Attachments / Technical document

Please double click with left mouse button on a paper clip symbol to open a file. You could also save a file when you click the symbol with the right mouse button.

- Operating instructions Emergency exit / Emergency release ACC-AZM40-PT-T/N 
- Operating instructions Retrofit kit ACC-AZM40-LEV-T/N 
- Operating instructions Lockout tag SZ40 
- Dimensional drawing Emergency exit / Emergency release ACC-AZM40-PT-T/N 
- Dimensional drawing Lockout tag SZ40 
- Dimensional drawing Mounting plate MP-AZM40 

4 Contact information

✉ K. A. Schmersal GmbH & Co. KG Möddinghofe 30 42279 Wuppertal DE
✉ info@schmersal.com
@ www.schmersal.com